



User Manual

for S6 Series Hybrid Inverter



Applicable models

S6-EH1P3.8K-H-US

S6-EH1P5K-H-US

S6-EH1P6K-H-US

S6-EH1P7.6K-H-S-US

S6-EH1P7.6K-H-L-US

S6-EH1P8K-H-US

S6-EH1P10K-H-US

S6-EH1P11.4K-H-US

Applicable System

Single phase system

1. Introduction	2
1.1 Product Description	2
1.2 Packaging	3
2. Safety & Warning	4
2.1 Safety	4
2.2 General Safety Instructions	4
2.3 Notice For Use	6
2.4 Notice for Disposal	6
3. Overview	7
3.1 Intelligent LED Indicators	7
3.2 Terminal Connection Overview	8
4. Installation	9
4.1 Select a Location for the Inverter	9
4.2 Mounting the Inverter	11
4.3 PE Cable Installation	14
4.4 PV Input Cable Installation	15
4.5 Battery Fuse Terminals	16
4.6 AC Cable Installation	17
4.7 Communication Terminals	18
5. Commissioning	25
5.1 Preparation of Commissioning	25
5.2 Commissioning Procedure	25
5.3 Shutdown Procedure	28
6. Troubleshooting	29
7. Maintenance	33
8. Appendix	45

1.1 Product Description

The Solis S6 Series is designed for residential hybrid systems, which can work with high voltage lithium ion batteries to maximize self-consumption rate.

This product can operate in both ON-Grid and OFF-Grid modes.

The Solis S6 hybrid inverter series contain the following models which are grid tied transformerless inverters:

S6-EH1P3.8K-H-US, S6-EH1P5K-H-US, S6-EH1P6K-H-US, S6-EH1P7.6K-H-S-US, S6-EH1P7.6K-H-L-US, S6-EH1P8K-H-US, S6-EH1P10K-H-US, S6-EH1P11.4K-H-US

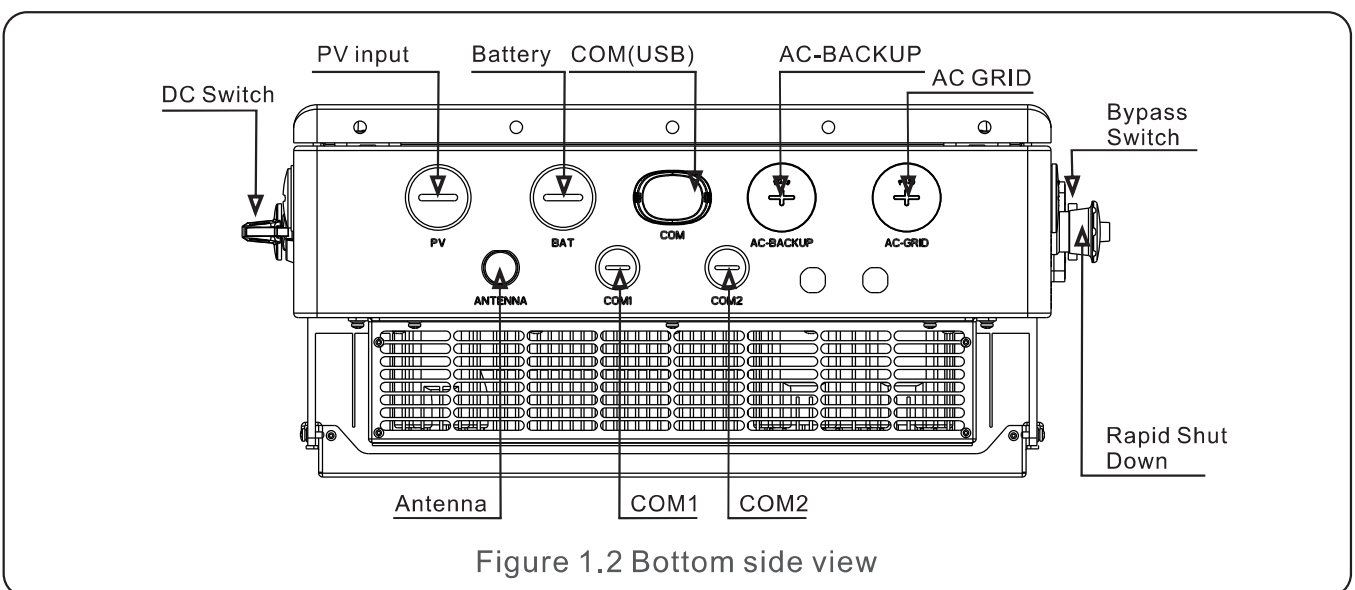
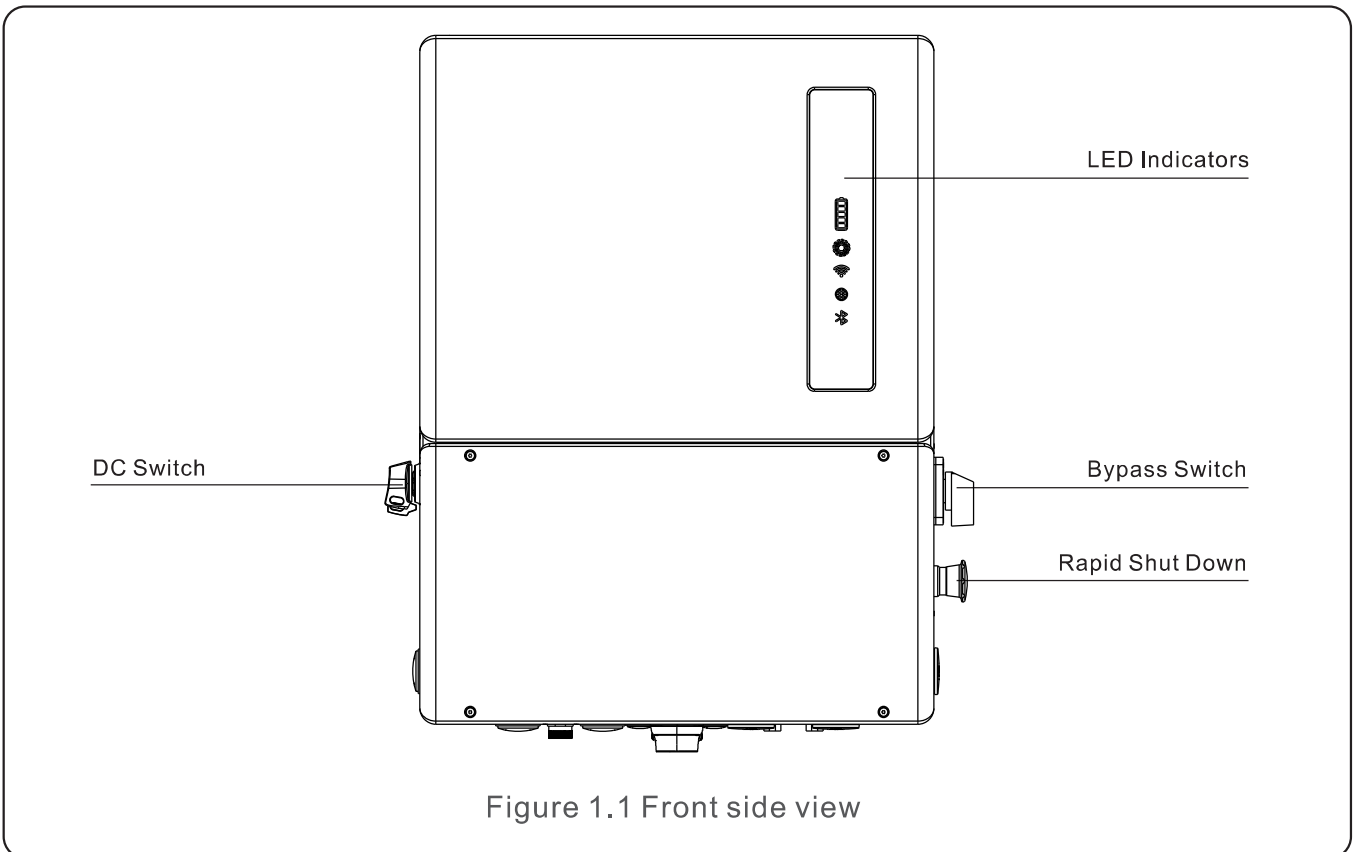

1.2 Packaging

Please ensure that the following items are included in the packaging with your machine:

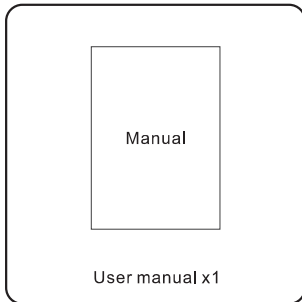
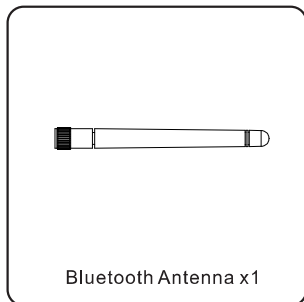
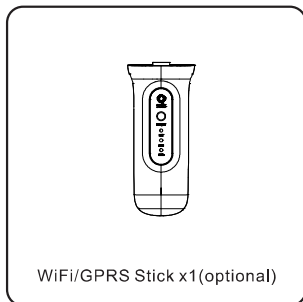
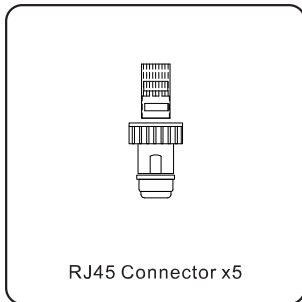
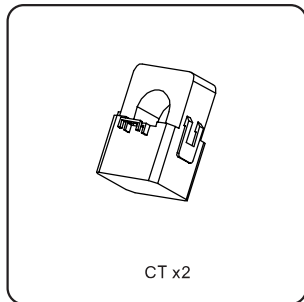
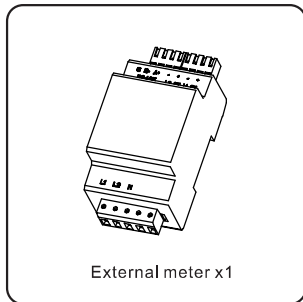
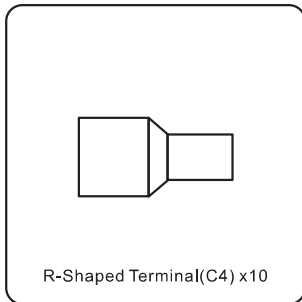
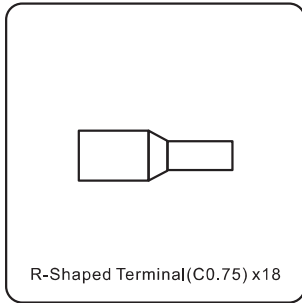
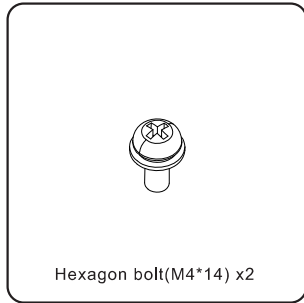
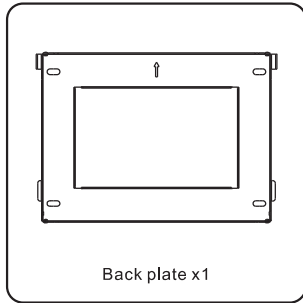
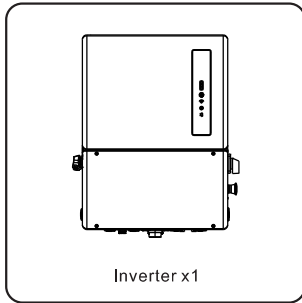

If anything is missing, please contact your local Solis distributor.

2.1 Safety

The following types of safety instructions and general information appear in this document as described below:



DANGER:

“Danger” indicates a hazardous situation which if not avoided, will result in death or serious injury.



WARNING:

“Warning” indicates a hazardous situation which if not avoided, could result in death or serious injury.



CAUTION:

“Caution” indicates a hazardous situation which if not avoided, could result in minor or moderate injury.



NOTE:

“Note” provides tips that are valuable for the optimal operation of your product.



WARNING: Risk of fire

Despite careful construction, electrical devices can cause fires.

- Do not install the inverter in areas containing highly flammable materials or gases.
- Do not install the inverter in potentially explosive atmospheres.

2.2 General Safety Instructions



WARNING:

Only devices in compliance with SELV (EN 69050) may be connected to the RS485 and USB interfaces.



WARNING:

Please don't connect PV array positive (+) or negative (-) to ground, it could cause serious damage to the inverter.



WARNING:

Electrical installations must be done in accordance with the local and national electrical safety standards.



WARNING:

Do not touch any inner live parts until 5 minutes after disconnection from the utility grid and the PV input.



WARNING:

To reduce the risk of fire, over-current protective devices (OCPD) are required for circuits connected to the inverter. The DC OCPD shall be installed per local requirements. All photovoltaic source and output circuit conductors shall have isolators that comply with the NEC Article 690, Part II. All Solis single phase inverters feature an integrated DC switch.



CAUTION:

Risk of electric shock, do not remove cover. There is no user serviceable parts inside, refer servicing to qualified and accredited service technicians.



CAUTION:

The PV array supplies a DC voltage when they are exposed to sunlight.



CAUTION:

The surface temperature of the inverter can reach up to 75°C (167 F). To avoid risk of burns, do not touch the surface of the inverter while it's operating. Inverter must be installed out of the reach of children.



NOTE:

PV module used with inverter must have an IEC 61730 Class A rating.



WARNING:

Operations below must be accomplished by licensed technician or Solis authorized person.



WARNING:

Operator must put on the technicians' gloves during the whole process in case of any electrical hazards.



WARNING:

AC BACKUP Port of S6 Series is not allowed to connect to the grid.



WARNING:

Please refer to the specification of the battery before configuration.

2.3 Notice for Use

The inverter has been constructed according to the applicable safety and technical guidelines. Use the inverter in installations that meet the following specifications ONLY:

1. Permanent installation is required.
2. The electrical installation must meet all the applicable regulations and standards.
3. The inverter must be installed according to the instructions stated in this manual.
4. The inverter must be installed according to the correct technical specifications.

2.4 Notice for Disposal



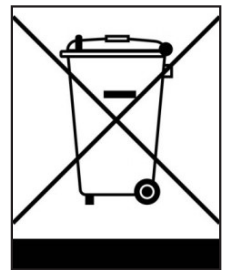

This product shall not be disposed of with household waste. They should be segregated and brought to an appropriate collection point to enable recycling and avoid potential impacts on the environment and human health. Local rules in waste management shall be respected .



3.1 Intelligent LED Indicators

There are five indicators on the The Solis S6-EH1P(3.8-11.4)K-H-US Series Inverter (Battery, Power, WiFi, RS485 and Bluetooth) which indicate the working status of the inverter.

The Bluetooth Antenna or WiFi datalogger shall be installed at the Antenna/COM port of the hybrid inverter before local debugging.

Light	Status	Description
 Battery	Blue Flashing every 3s	Battery discharging.
	Blue Flashing every 1.5s	Battery charging.
	Blue Solid ON	Idle.
	Yellow Solid ON	Battery Warning.
 Power	Blue Solid ON	Normally Operating.
	Yellow Solid ON	Warning.
	Red Solid ON	Alarm.
 WiFi	Blue Solid ON	COM Port is using.
	OFF	COM Port is not used.
 RS485	Blue Solid ON	RS485 Port is using.
	OFF	RS485 Port is not used.
 Bluetooth	Blue Solid ON	Bluetooth Port is using.
	OFF	Bluetooth Port is not used.



NOTE: Battery/WiFi/RS485/Bluetooth indicators will automatically turn off after 1 minute. The Power indicator will remain on with lower brightness. Short press the Power indicator can wake up all indicators.

3.2 Terminal Connection Overview

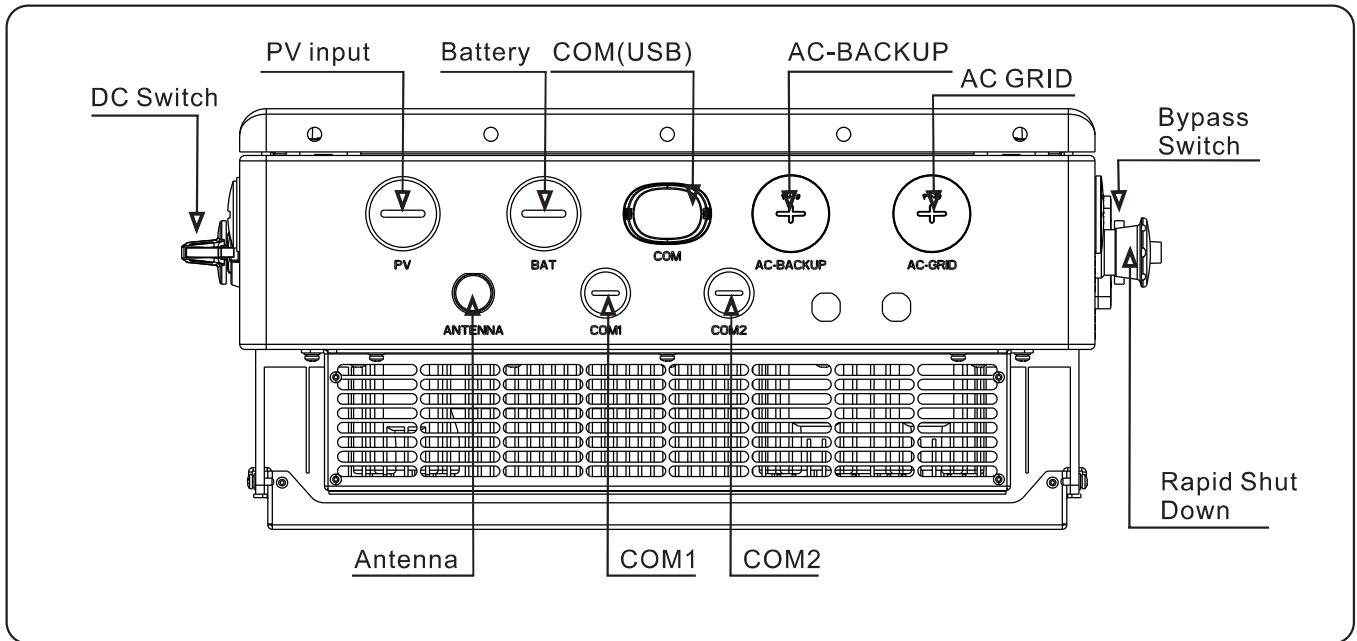

Name	Description
DC Switch	The switch is used to turn off the PV inputs
PV Input	conduit for passing through PV cables
Battery	conduit for passing through Battery cables
COM(USB)	USB Type communication port for connecting Solis data loggers
AC-BACKUP	conduit for passing through AC cables for backup circuit
AC-GRID	conduit for passing through AC cables for grid circuit
Antenna	Antenna connection for local bluetooth signal
COM1/COM2	conduits for communication cables
Rapid Shut Down	Rapid shutdown emergency button to power off the transmitter and module level receivers
Bypass Switch	Bypass switch for backup circuit. Mode 0 - Backup load is disconnected from the system Mode 1 - Backup load is supported by the Grid Mode 2 - Backup load is supported by the Backup circuit of the inverter

4.1 Select a Location for the Inverter

To select a location for the inverter, the following criteria should be considered:

- Exposure to direct sunlight may cause output power derating. It is recommended to avoid installing the inverter in direct sunlight.
- It is recommended that the inverter is installed in a cooler ambient which doesn't exceed 104F/40C.

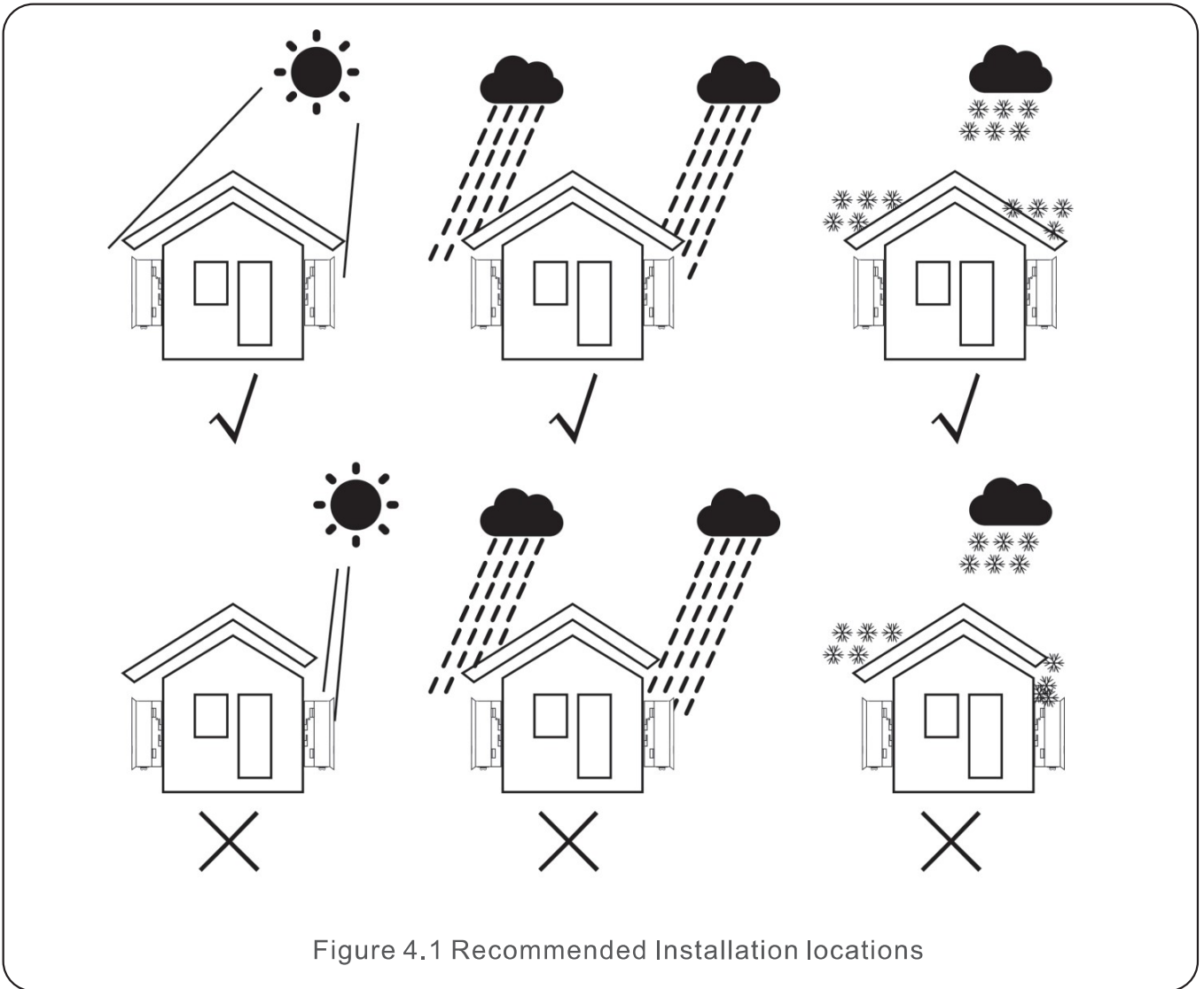

Figure 4.1 Recommended Installation locations



WARNING: Risk of fire

Despite careful construction, electrical devices can cause fires.

- Do not install the inverter in areas containing highly flammable materials or gases.
- Do not install the inverter in potentially explosive atmospheres.
- The mounting structure where the inverter is installed must be fireproof.

- Install on a wall or strong structure capable of bearing the weight of the machine (30kg).
- Install vertically with a maximum incline of +/- 5 degrees: exceeding this may cause output power derating.
- To avoid overheating, always ensure the flow of air around the inverter is not blocked. A minimum clearance of 300mm(11.8in) should be kept between inverters or objects and 500mm(19.6in) clearance between the bottom of the machine and the ground.

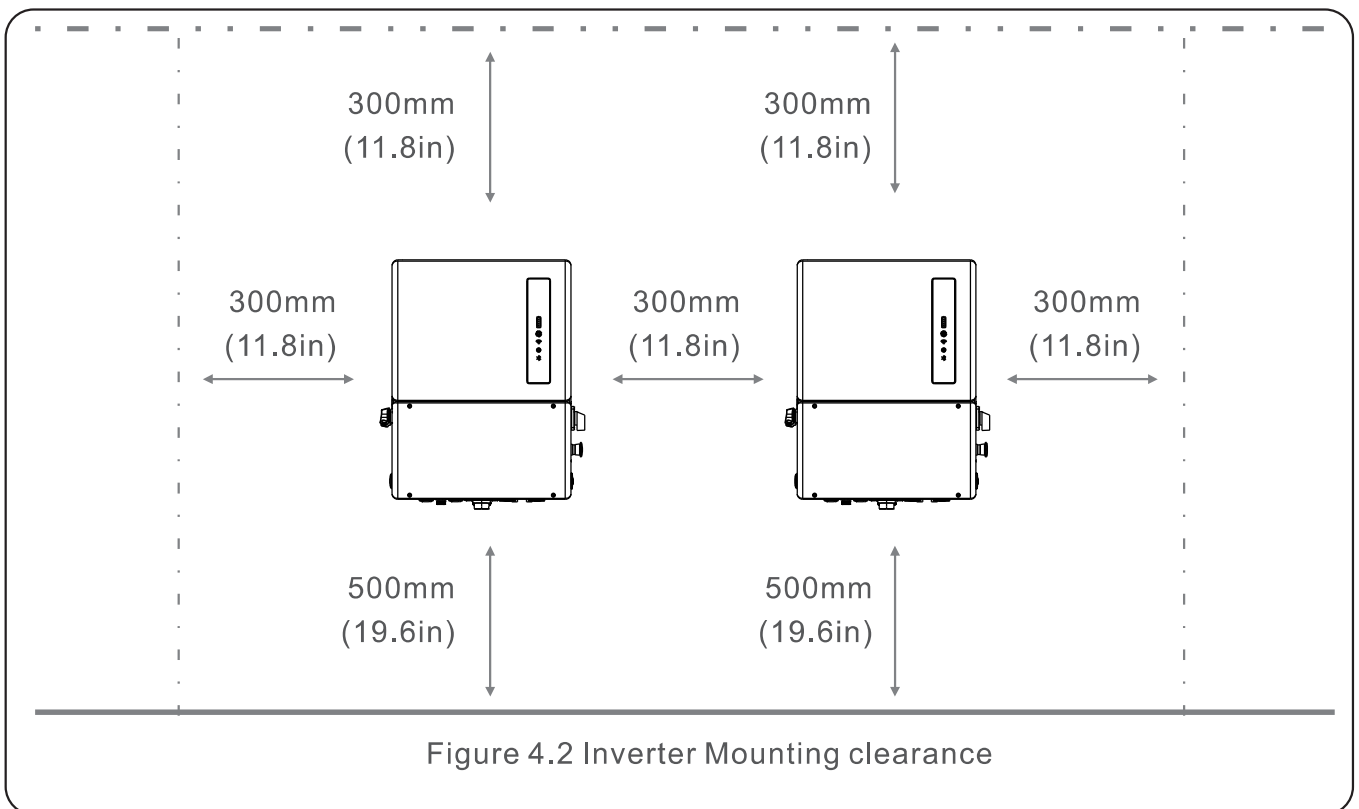

- Visibility of the LEDs should be considered.
- Adequate ventilation must be provided.



NOTE:

Nothing should be stored on or placed against the inverter.

4.2 Mounting the Inverter

Dimensions of mounting bracket:

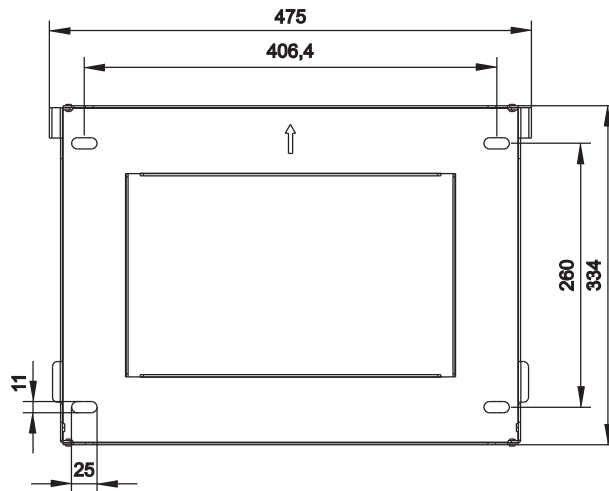

Figure 4.3 Inverter wall mounting

Once a suitable location has been found according to 4.1 using figures 4.3 and 4.4 mount the wall bracket to the wall.

The inverter shall be mounted vertically.

The steps to mount the inverter are listed below:

1. Select the mounting height of the bracket and mark the mounting holes.
For brick walls, the position of the holes should be suitable for the expansion bolts.

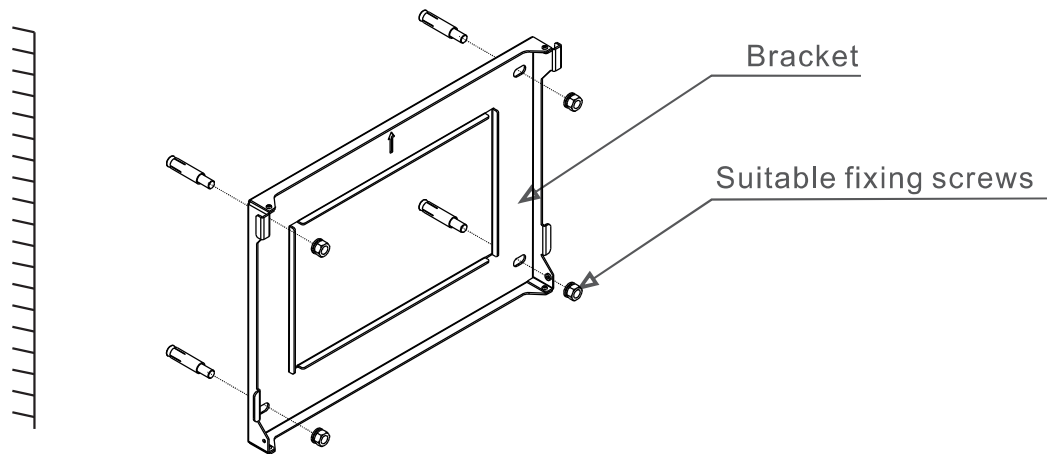

Figure 4.4 Fix bracket on the wall



WARNING:

The inverter must be mounted vertically.

2. Lift up the inverter (be careful to avoid body strain) and align the back bracket on the inverter with the convex section of the mounting bracket. Hang the inverter on the mounting bracket and ensure the inverter is secure (see Figure 4.5)

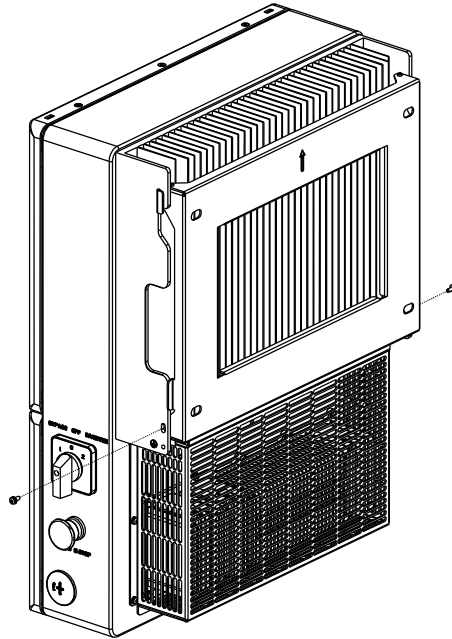

Figure 4.5 Wall Mount Bracket



NOTE:

The installation shall meet the National Electrical Code, ANSI/NFPA 70 and Canadian Electrical Code wiring methods.

	Cross-sectional Dimension	Functionality	Where to connect
PV Cables	12-10AWG, 90°C Copper	PV DC source	From PV strings to terminal "DC+" and "DC-"
Battery Cables	10-8AWG for 3.8K-7.6K-(S), 6AWG for 7.6K-(L)-11.4K, 90°C Copper	Battery DC source	From Battery modules to terminal "BAT+" and "BAT-"
AC Grid Cables	12AWG for 3.8K, 12-10AWG for 5K, 10AWG for 6K, 8AWG for 7.6K-8K, 6AWG for 10K-11.4K, 90°C Copper	AC Grid connection	From incoming AC distribution box to terminal AC-GRID "L1" and "L2"
AC Backup Cables	12AWG for 3.8K, 12-10AWG for 5K, 10AWG for 6K, 8AWG for 7.6K-8K, 6AWG for 10K-11.4K, 90°C Copper	AC Backup connection	From backup loads to terminal AC-BACKUP "L1", and "L2"
Ground Cables	12AWG for 3.8K, 12-10AWG for 5K, 10AWG for 6K, 8AWG for 7.6K-8K, 6AWG for 10K-11.4K, 90°C Copper	Grounding connection (Dimension depends on AC backup cables and AC grid cables)	From AC groundings to copper bar inside the wiring box
Meter COM cable	22-16AWG, 90°C Copper	Communication between inverter to Meter	From meter to terminal MT "A" and "B". Details refer to "4.2.2 Install the energy meter"
CAN Cable	22-16AWG, 90°C Copper	Communication between inverter to Battery	From battery to terminal CAN "L" and "H". Details refer to 4.2.3 Install the battery
BMS Cable	22-16AWG, 90°C Copper	Not Applicable in these systems	Not Applicable in these systems
Cover External Grounding Cable	12AWG for 3.8K, 12-10AWG for 5K, 10AWG for 6K, 8AWG for 7.6K-8K, 6AWG for 10K-11.4K, 90°C Copper	Ground the inverter cover	From grounding screw on the inverter external cover to the ground
Datalogger (Optional)	Pre-assembled Plug	Modbus/Sunspec Communication between the system and the Solis monitoring portal	USB COM port at the bottom of the inverter. (Detailed info please refer to Solis datalogger user manual)

Table 4.1 Wire Specification

4.3 PE Cable Installation

An external ground connection is provided at the right side of inverter.

Prepare OT terminals: M4. Use proper tooling to crimp the lug to the terminal.

Connect the OT terminal with ground cable to the right side of inverter. The torque is 2N.m.

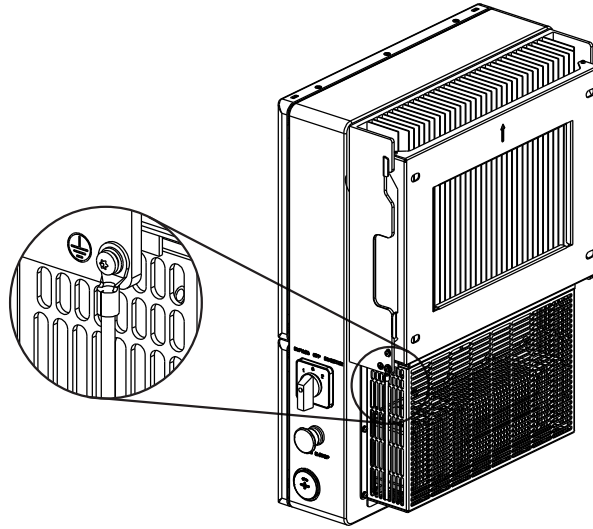

Figure 4.6 Connect the external grounding conductor

4.4 PV Input Cable Installation

Please ensure the following before connecting the inverter:

- Ensure the voltage of the PV string will not exceed the max DC input voltage (600Vdc). Violating this condition will void the warranty.
- Ensure the polarity of the PV terminals and battery are correct.
- Ensure the DC-switch, battery, AC-BACKUP, and AC-Grid are all in their off-states.
- Ensure the PV resistance to ground is higher than 20K ohms.

PV wire requirements: 12-10AWG 90°C Copper

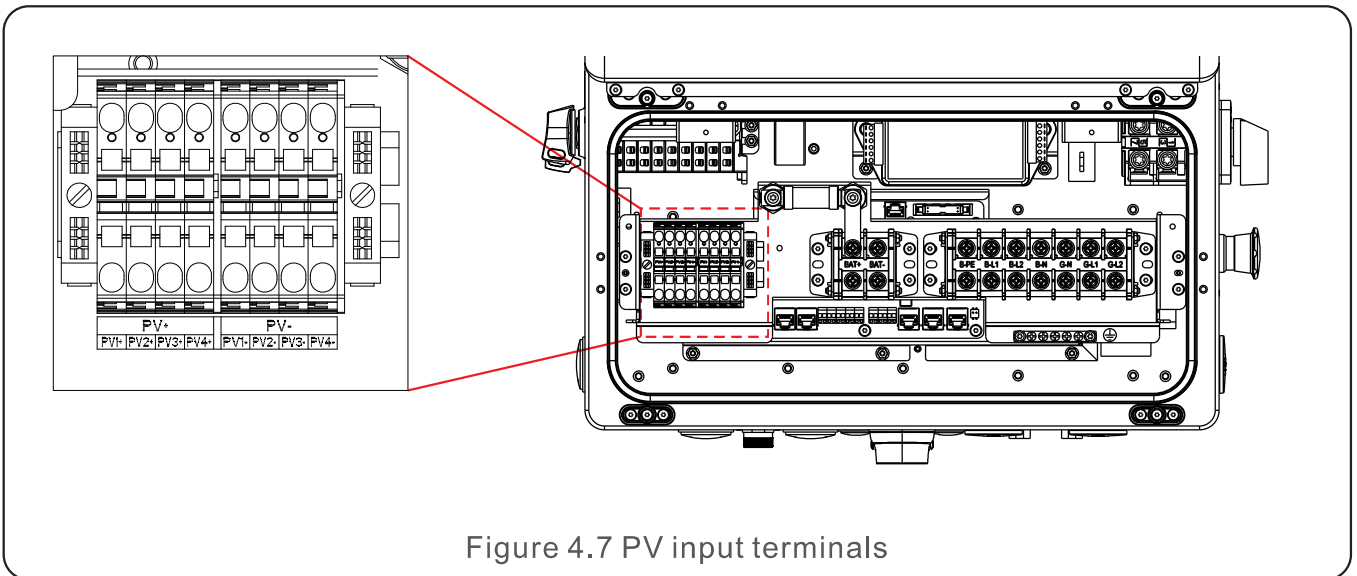

Figure 4.7 PV input terminals



CAUTION:

If DC inputs are accidentally reversely connected or inverter is faulty or not working properly, it is NOT allowed to turn off the DC switch. Otherwise it may cause DC arc and damage the inverter or even lead to a fire disaster.

The correct actions are:

*Use a clip-on ammeter to measure the DC string current.

*If it is above 0.5A, please wait for the solar irradiance reduces until the current decreases to below 0.5A.

*Only after the current is below 0.5A, you are allowed to turn off the DC switches and disconnect the PV strings.

* In order to completely eliminate the possibility of failure, please disconnect the PV strings after turning off the DC switch to avoid secondary failures due to continuous PV energy on the next day.

Please note that any damages due to wrong operations are not covered in the device warranty.

4.5 Battery Fuse Terminals

Battery power cables should be connected to the battery fuse terminals in the wiring box through the BAT conduit.

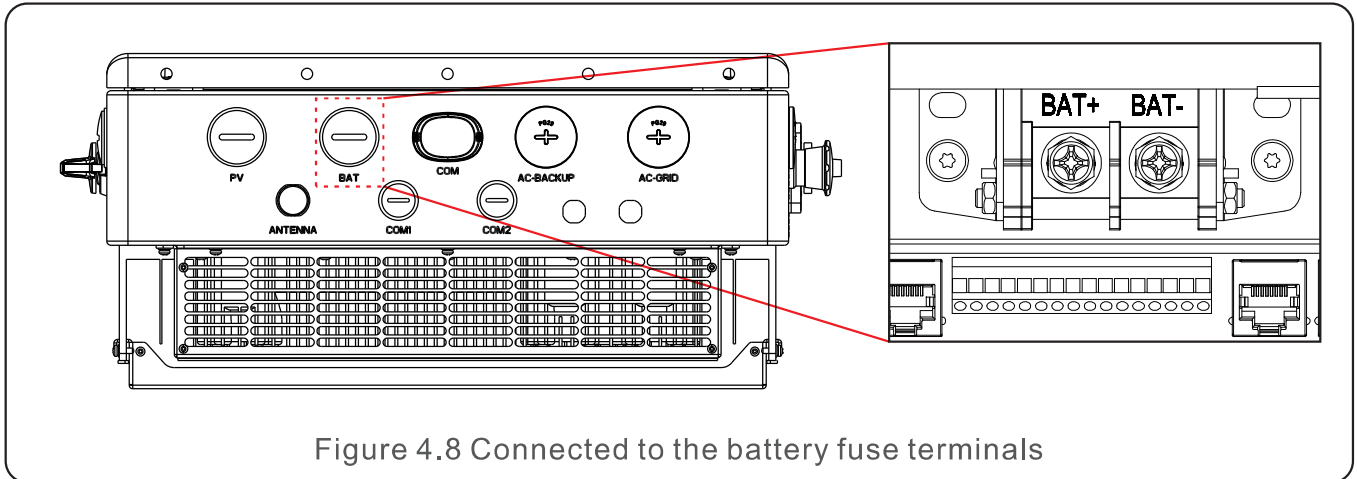

Figure 4.8 Connected to the battery fuse terminals

Model	S6-EH1P(3.8-7.6)K-H-(S)	S6-EH1P(7.6-11.4)K-H-(L)
Battery Cable Cross Sectional Area	10-8 AWG	6 AWG
OT Terminal	M6	M6
Torque	4-5N.m	4-5N.m
Battery Conduit Diameter	34.5mm	34.5mm

Table 4.2 Battery power cable requirement



Note:

The battery fuses in the wiring box are replaceable.
The replacement must be done by Solis authorized technicians only.
Fuse specification: 750V, 63A.



Note:

Before connecting the battery, please carefully read the user manual of the battery and perform the installation exactly as the battery manufacturer requests.

4.6 AC Cable Installation

There are two AC terminals and the assembly steps for both are the same.

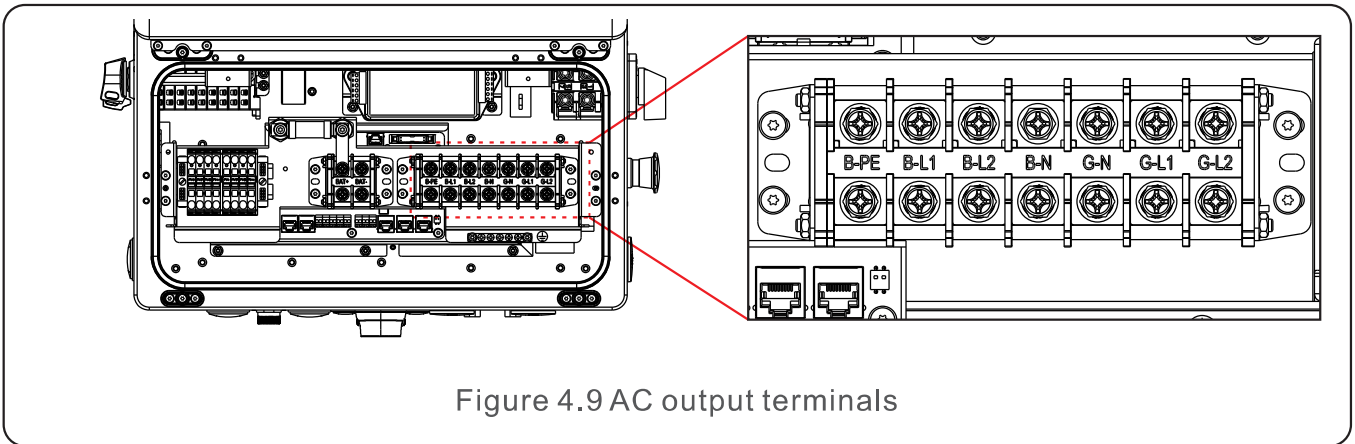

Figure 4.9 AC output terminals

Model	S6-EH1P3.8K-H	S6-EH1P5K-H	S6-EH1P6K-H	S6-EH1P (7.6-8)K-H	S6-EH1P (10-11.4)K-H
AC Grid Cable Cross Sectional Area	12 AWG	12-10 AWG	10 AWG	8 AWG	6 AWG
AC Backup Cable Cross Sectional Area	12 AWG	12-10 AWG	10 AWG	8 AWG	6 AWG
Torque	4.5N.m	4.5N.m	4.5N.m	4.5N.m	4.5N.m
OT Terminal	M6	M6	M6	M6	M6
Grounding Bar Specification	12 AWG	12-10 AWG	10 AWG	8 AWG	6 AWG
AC Grid Conduit Diameter	37.3mm	37.3mm	37.3mm	37.3mm	37.3mm
AC Backup Conduit Diameter	37.3mm	37.3mm	37.3mm	37.3mm	37.3mm

Table 4.3 AC wire specification

1. Lead the AC cables into the corresponding conduit.
2. Please refer to the terminal marks to connect the AC wires accordingly.
 - B-L1 -> AC Backup L1
 - B-L2 -> AC Backup L2
 - B-N -> AC Backup Neutral
 - G-N -> AC Grid Neutral
 - G-L1 -> AC Grid L1
 - G-L2 -> AC Grid L2



Note:

Do not mismatch the AC terminals, otherwise the inverter may not function properly.

Over-Current Protection Device (OCPD) for the AC side

To protect the inverter's AC connection line, we recommend installing a device for protection against over-current and leakage, with the following characteristics noted in Table 4.4:

Inverter	Rated voltage(V)	Grid Max Output Current (Amps)	Grid Max Input Current (Amps)	Current for protection device (A)
S6-EH1P3.8K-H-US	220/110	17.3	25.9	30
S6-EH1P5K-H-US	220/110	22.7	34.1	40
S6-EH1P6K-H-US	220/110	27.3	40.9	50
S6-EH1P7.6K-H-S-US	220/110	34.5	51.8	60
S6-EH1P7.6K-H-L-US	220/110	34.5	51.8	60
S6-EH1P8K-H-US	220/110	36.4	54.5	65
S6-EH1P10K-H-US	220/110	45.5	68.2	80
S6-EH1P11.4K-H-US	220/110	51.8	77.7	90

Table 4.4 Rating of grid OCPD

4.6 Communication Terminals

4.6.1 Communication Terminal Definition

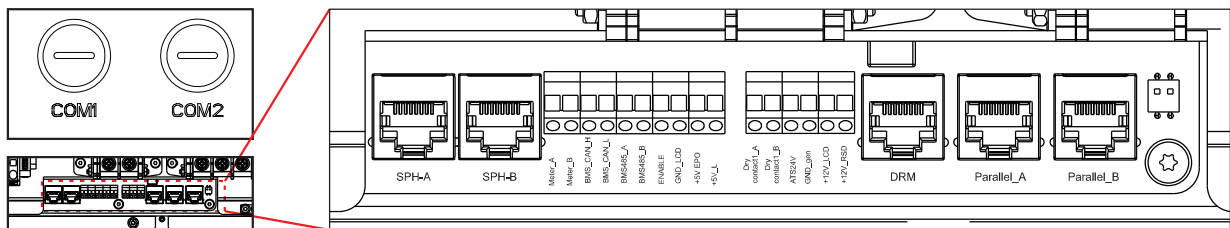

Figure 4.10 Communication port

From left to right, the communication terminals consist of 16 ports.

NO.	Port	Spec	Function
1	Meter_A	22-16 AWG	Used for RS485 communication between inverter and the compatible smart meter. It is necessary to realize the normal hybrid control logics.
2	Meter_B		
3	BMS_CAN_H		Used for CAN communication with compatible battery.
4	BMS_CAN_L		
5	BMS485_A		Used for RS485 communication with compatible battery.
6	BMS485_B		
7	ENABLE		
8	GND_LCD		Emergency Power Off Signal.
9	+5V EPO		
10	+5V_L		(Reserved)Dry contact for generator connection.
11	Dry contact1_A		
12	Dry contact1_B		(Reserved)For ATS connection.
13	ATS24V		
14	GND_gen		(No Need Connect)Power Supply for control board.
15	+12V_LCD		
16	+12V_RSD		(No Need Connect)Power Supply for MLRSD Transmitter.
17	Parallel_A	RJ45 Port	(Reserved) For parallel connection.
18	Parallel_B		
19	DRM		Not Applicable.
20	COM	USB Type Port	For inverter remote monitoring connection.
21	COM1/COM2	Conduit	Empty conduit for running through communication cables.
22	ANTENNA		For connecting the bluetooth antenna.

Table 4.5 communication terminals



Note:

Diameter of the conduits for COM1 and COM2 is 22.5 mm. Please arrange suitable communication wires to run through the two conduits.



Note:

Communication Terminal Connection Steps:

1. Use slot type screwdriver to press the block on the top.
2. Insert the exposed copper part of the cable into the terminal.
3. Remove the screwdriver and the terminal will clamp down on the exposed copper.
4. Give the cable a gentle tug to ensure that it is firmly secured.

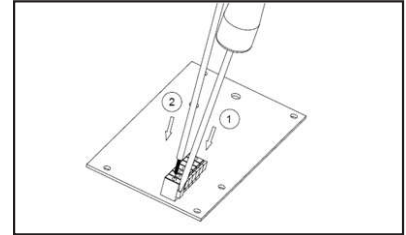

4.6.2 Meter Communication

AGF-AE-D smart meter is provided in the accessory package, please follow the following diagram to connect the meter communication wires to the Meter_A and Meter_B pins on the communication terminal.

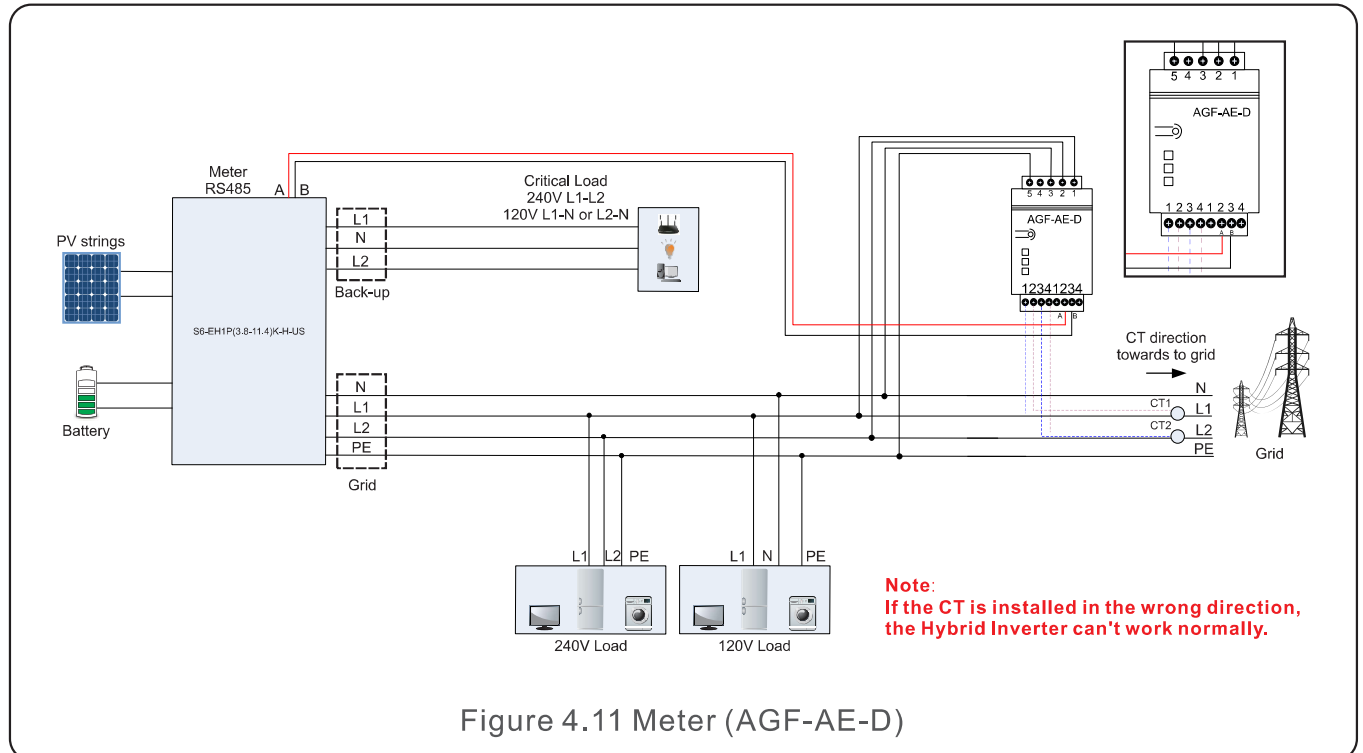

Figure 4.11 Meter (AGF-AE-D)

4.6.3 Battery Communication

CAN Communication Terminals: BMS_CAN_H / BMS_CAN_L

RS485 Communication Terminals: BMS485_A/BMS485_B/ENABLE/GND_LCD.

- BYD Battery

For BYD Battery-BoxH, BMS_CAN_H / BMS_CAN_L are used

The detailed connection is shown in the following figure.

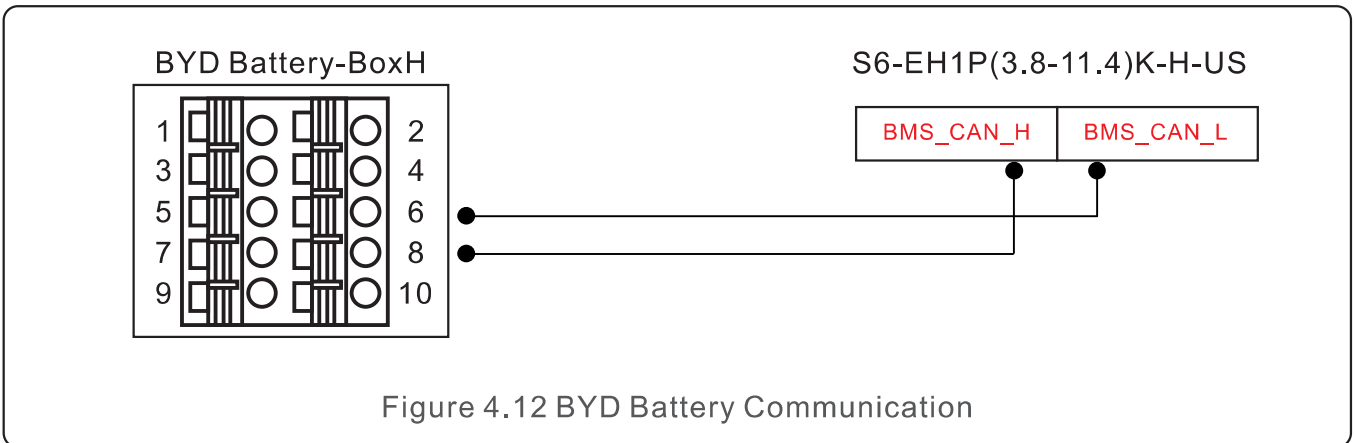

Figure 4.12 BYD Battery Communication

- LG Battery

For LG RESU10H Type R, BMS485_A/BMS485_B/ENABLE/GND_LCD are used

The detailed connection is shown in the following figure.

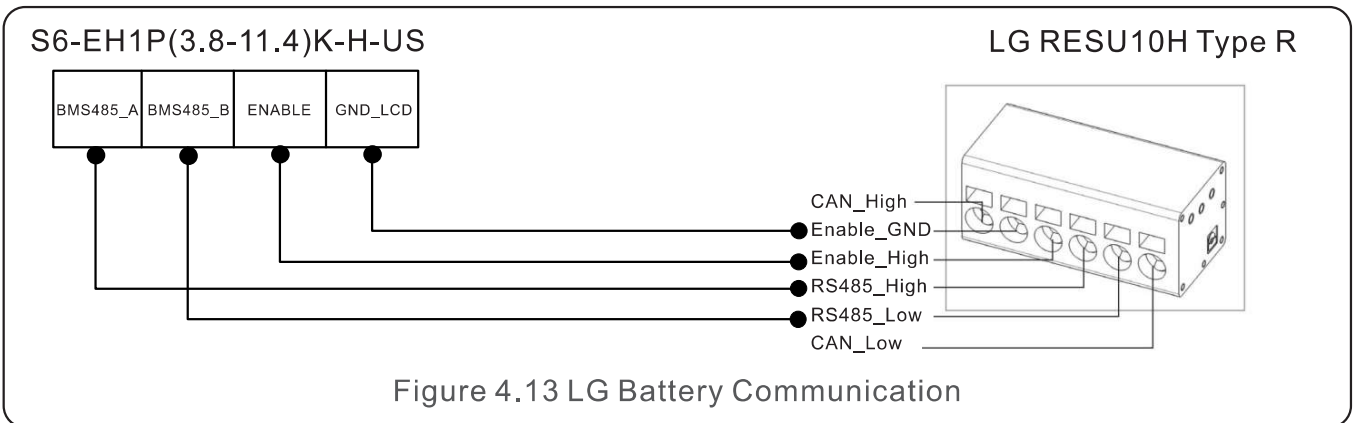

Figure 4.13 LG Battery Communication



Note:

When working with LG batteries in OFF-GRID mode, due to the circuit design of the battery, some specific loads may cause the inverter to display battery alarm. This is a normal situation and the system will recover once the grid is available.

- Pylontech Battery

For Pylon Force-H1, BMS_CAN_H / BMS_CAN_L are used.

The detailed connection is shown in the following figure 4.14.

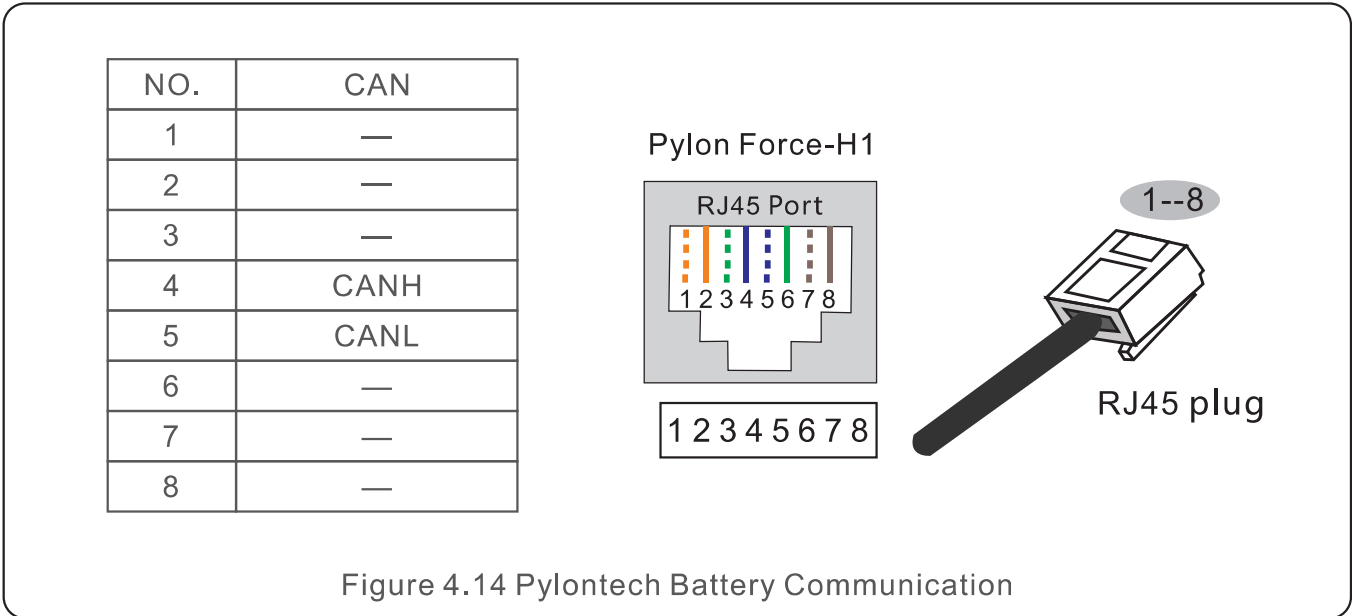

- Soluna Battery

For Soluna 10K HV, BMS_CAN_H / BMS_CAN_L are used.

The detailed connection is shown in the following figure 4.15.

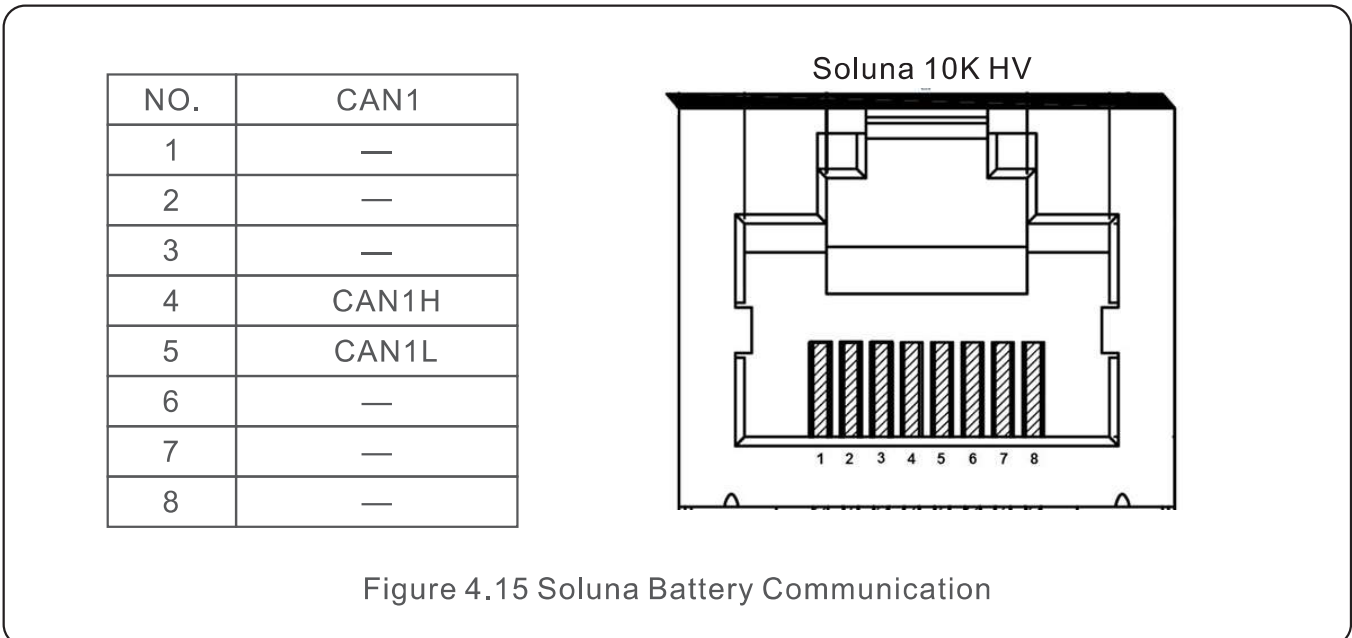

4.6.4 Inverter Remote Monitoring Connection

The inverter can be remotely monitored via WiFi, LAN or 4G.

The USB type COM port at the bottom of the inverter can connect to different kinds of Solis data loggers to realize the remote monitoring on Soliscloud platform.

To install Solis data loggers, please refer to corresponding user manuals of Solis data loggers.

The Solis data loggers are optional and can be purchased separately.

Dust cover is provided the inverter package in case the port is not used.



WARNING:

The USB type COM port is only allowed to connect Solis data loggers. It is forbidden to be used for other purposes.

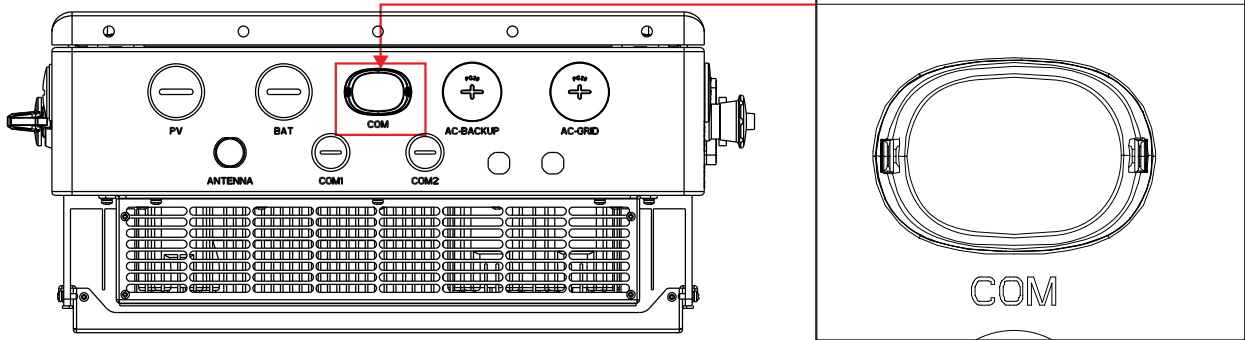

Figure 4.16

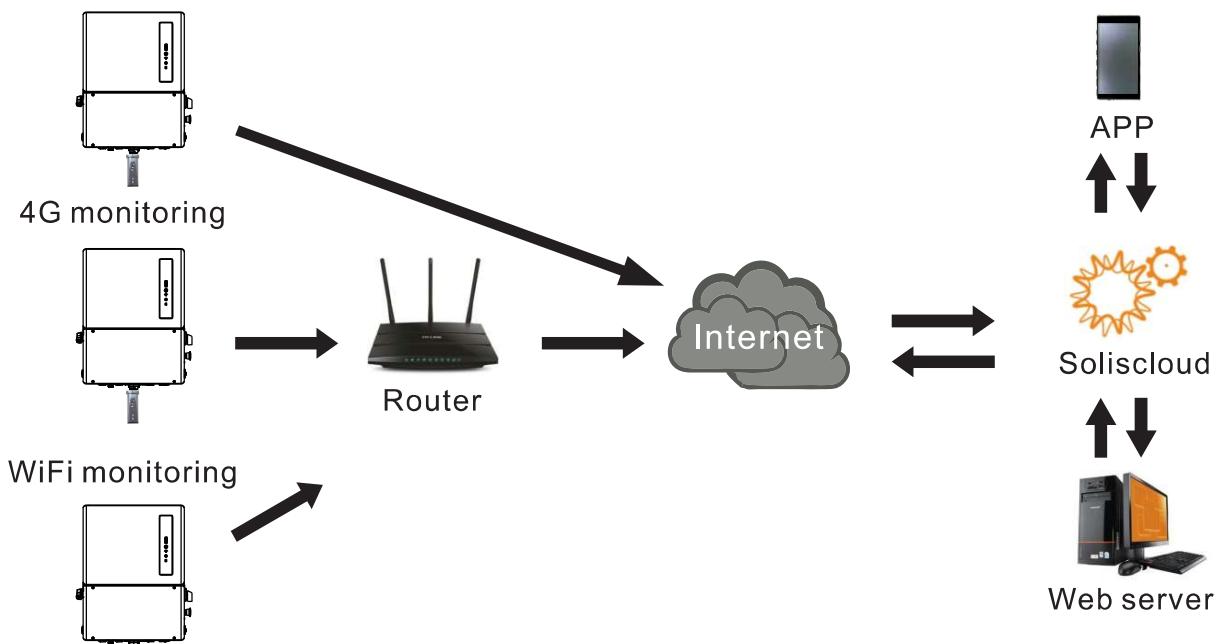

Figure 4.17 Wireless communication function

4.6.5 Local Bluetooth Antenna Connection

An antenna is provided in the accessory package, please insert the antenna to the “ANTENNA” port at the bottom of the inverter to enhance the local bluetooth signal strength.

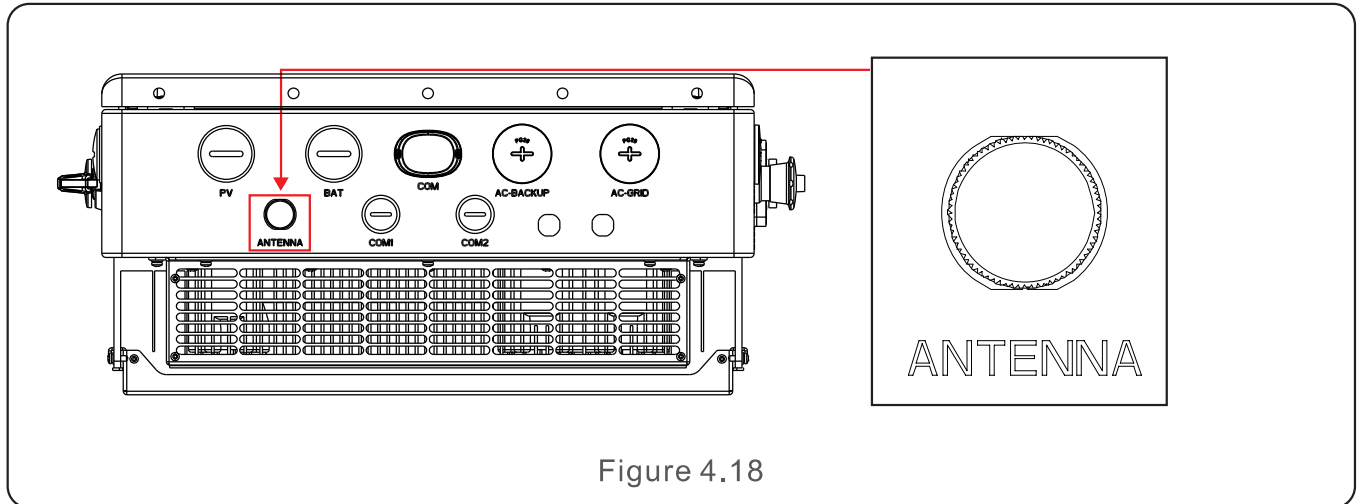

Figure 4.18

5.1 Preparation of Commissioning

- Ensure all the devices are accessible for operation, maintenance and service.
- Check and confirm that the inverter is firmly installed.
- Space for ventilation is sufficient for one inverter or multiple inverters.
- Nothing is left on the top of the inverter or battery module.
- Inverter and accessories are correctly connected.
- Cables are routed in safe place or protected against mechanical damage.
- Warning signs and labels are suitably affixed and durable.
- Bluetooth Antenna has been connected to the Antenna port of the inverter.
- An Android or IOS mobile phone with Bluetooth function is available.
- Soliscloud APP is installed on the mobile phone.

There are three ways to download and install the latest APP:

1. You can visit www.soliscloud.com to download the latest version APP.
2. You can search “**Soliscloud**” in Google Play or App Store.
3. You can scan this QR code below to download “**Soliscloud**”.



5.2 Commissioning Procedure

Step 1: Measure DC voltage of PV strings and battery and ensure the polarity is correct.

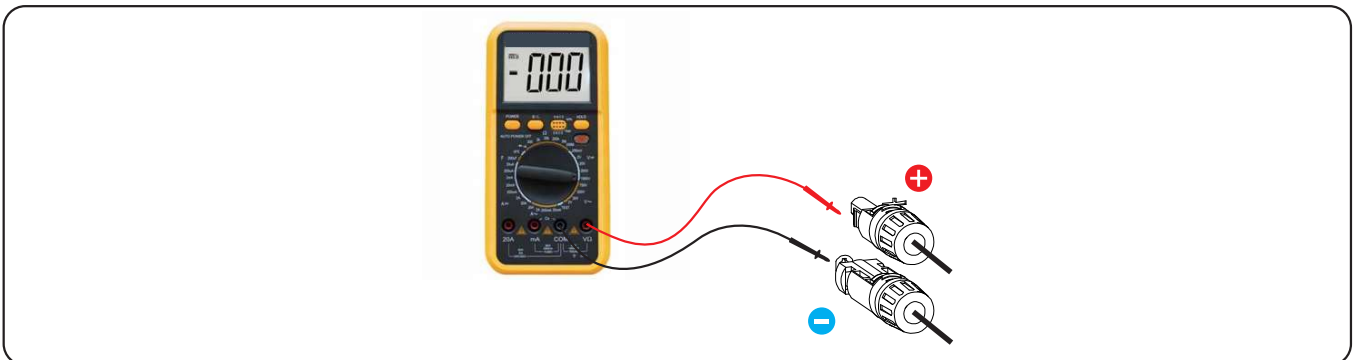

Step 2: Measure AC voltage and frequency and ensure they are within local standard.

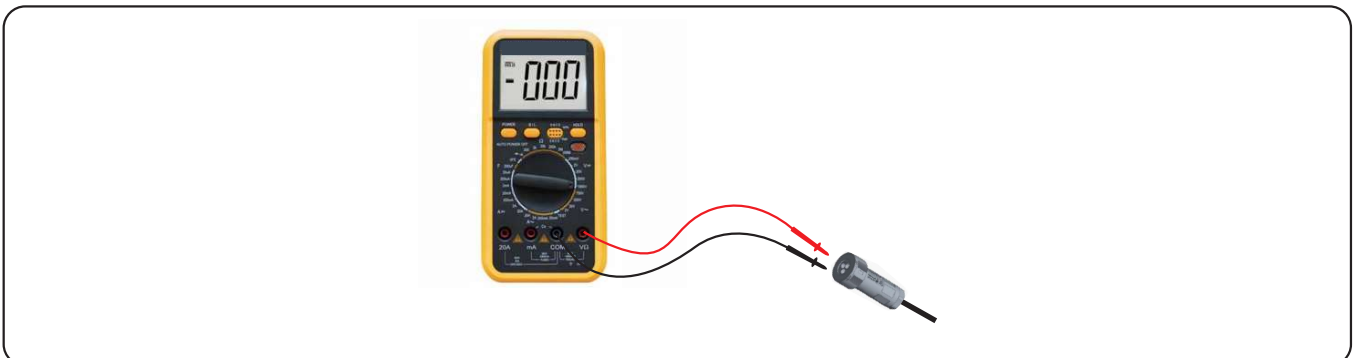

Step 3: Switch on the external AC breaker to power on the inverter control board.
(Bluetooth signal available)

Step 4: Connect with Bluetooth.

Turn on Bluetooth switch on your mobile phone and then open the Soliscloud APP. Click “More Tools”->”Local Operation”->”Connect with Bluetooth”

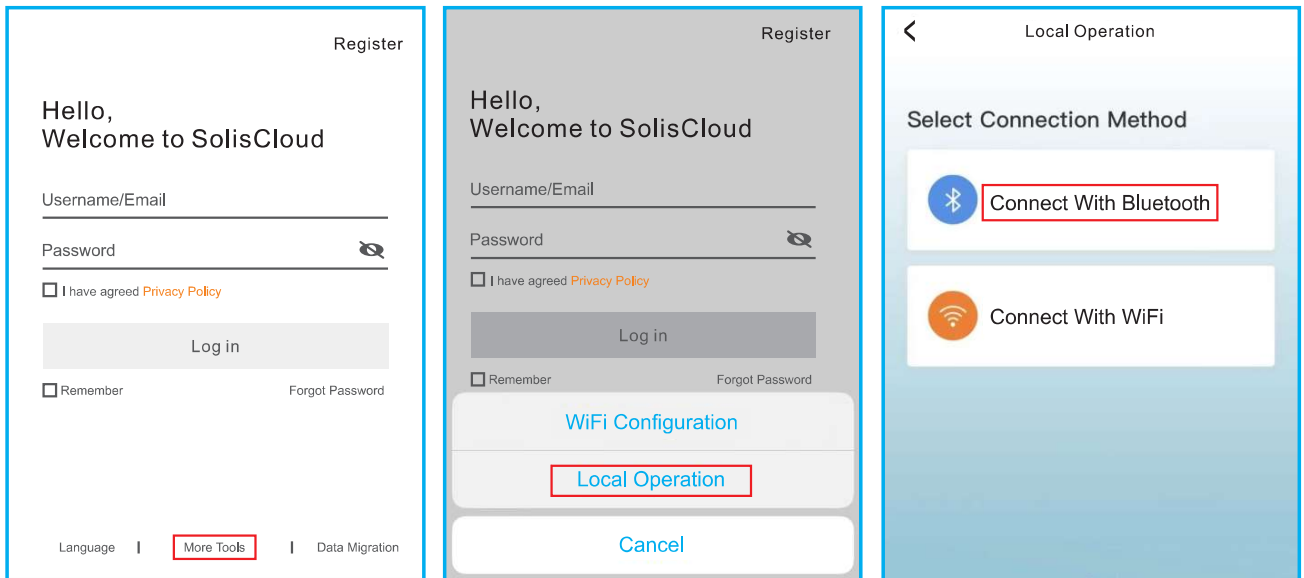

Step 5: Select the Bluetooth signal from the inverter. (Bluetooth Name: Inverter SN)

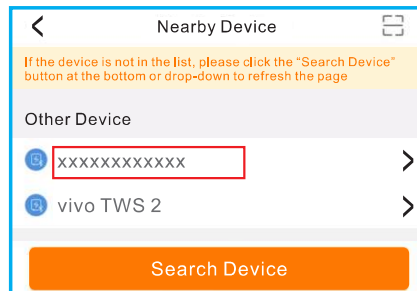

Step 6: Login account.

If you are the installer, please select the account type as Installer. If you are the plant owner, please select the account type as owner. Then set your own initial password for control verification. (The first log-in must be finished by installer in order to do the initial set up)

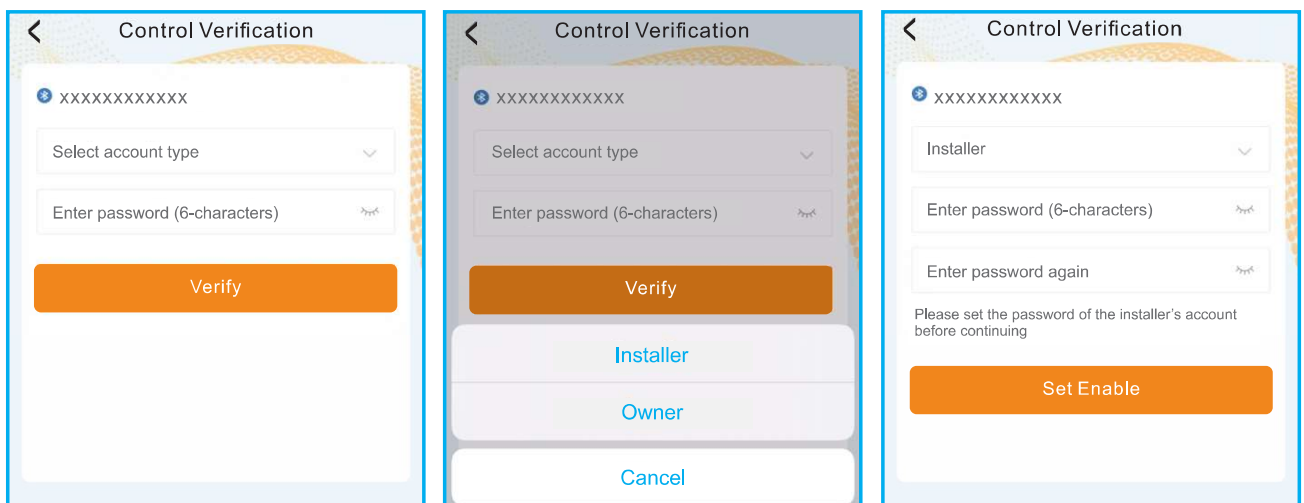

Step 7: After the log in for the first time, initial settings are required.

Step 7.1: Set the inverter Date and Time.

You can set to follow the time on your mobile phone.

Step 7.2: Set the battery model.

It must be based on the battery model that is actually connected to the inverter.

If there is no battery connected for the moment, please select “No Battery” to avoid alarms.

The default setting for battery over discharge SOC is 20%, force charge SOC is 10%.

Step 7.3: Set the meter setting.

It must be based on the meter type that is actually connected to the inverter.

If there is no meter connected for the moment, please select “No Meter” to avoid alarms.

It is suggested to install the meter at the system grid connection point and select “Meter in Grid”.

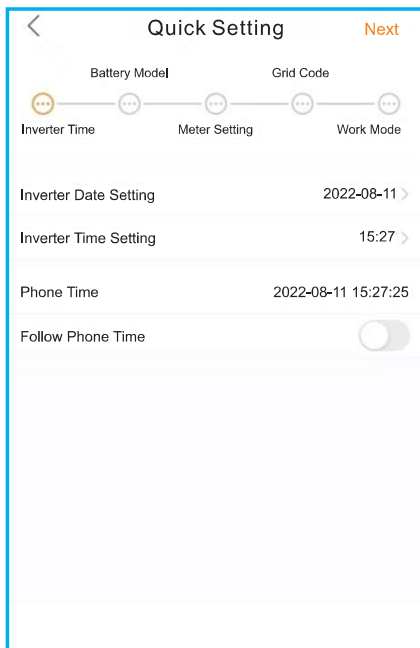

Step 7.1

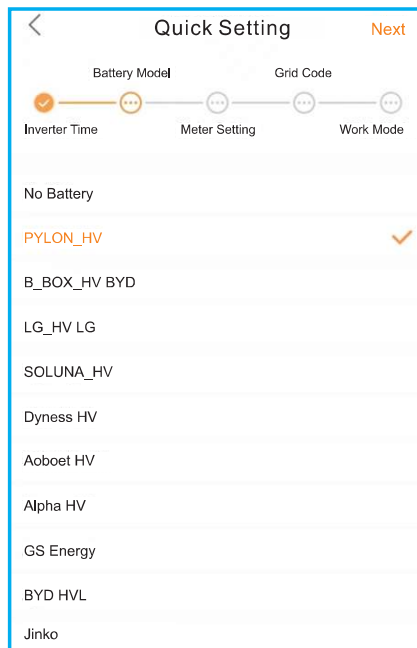

Step 7.2

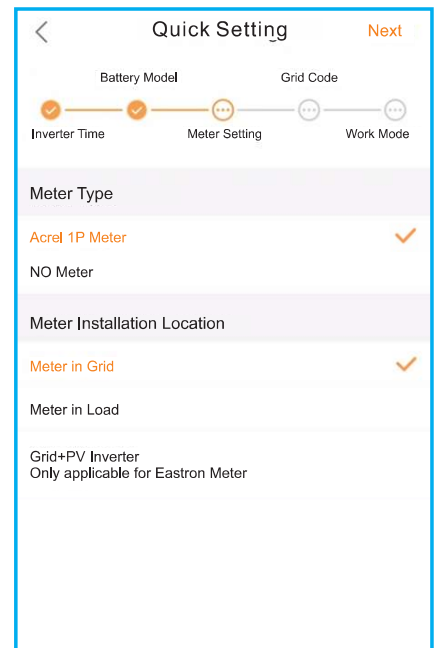

Step 7.3

Step 7.4: Set the grid code setting.

Please select the grid code based on the local grid network requirements.

Step 7.5: Set the work mode setting.

Recommended setting is Self-Use Mode. This mode can maximize the use of PV power generation for household electricity, or store it in batteries and use it for household electricity.

If need manually control the battery charging and discharging with respect to time, please use the Time of Use switch and the following set points. The “Allow Grid Charging” is recommended to be turned on (If turned off, the inverter will not force charge the battery and battery could potentially go to sleep).

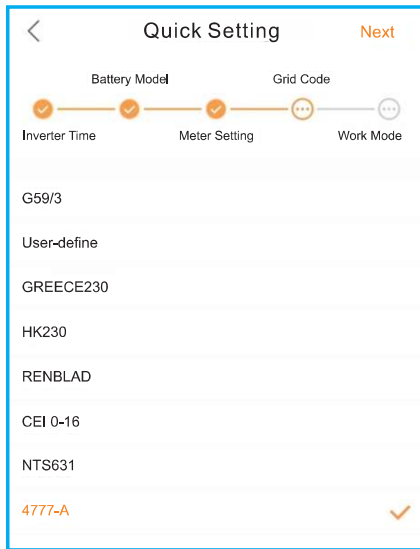

Step 7.4

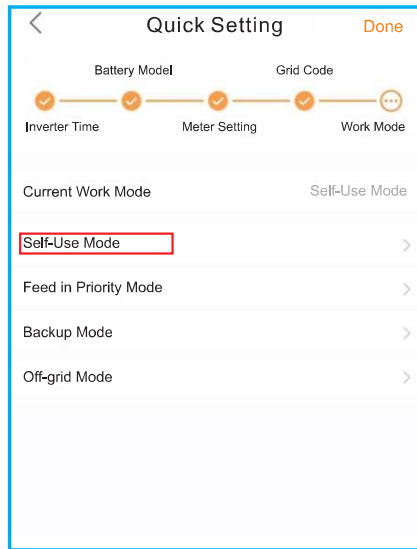

Step 7.5(1)

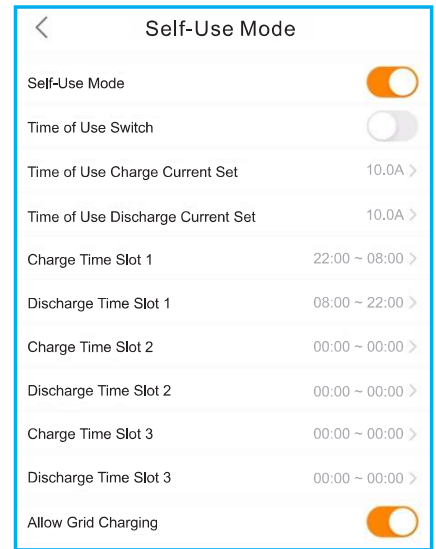

Step 7.5(2)

Step 8: Setup complete.

Now the initial settings on the inverter have been set and you can switch on the inverter DC switch and switch on battery breaker to start up the system. You can also explore in the APP to check the operating data, alarm message or other advanced settings.

Step 9: Change Password.

If the Owner forgot the password, please contact the installer. Installer log in and go to “Setting”->”More”->”Change Password” to reset the password for owner’s account.

If Installer forgot the password, please contact Solis service team.

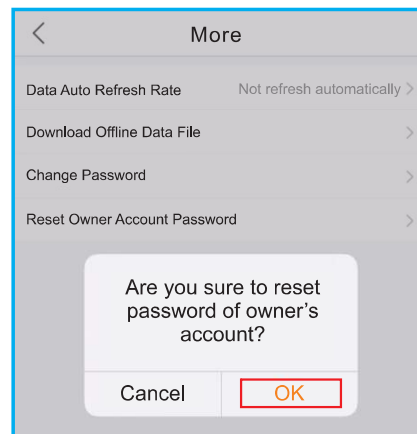
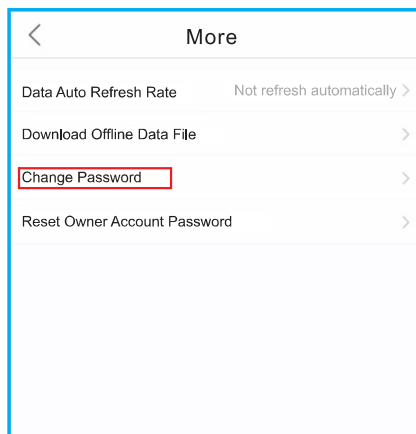

5.3 Shutdown procedure

Step 1. Turn off the AC breaker at the grid connection point.

Step 2. Turn off the DC switch of the inverter.

Step 3. Turn off the battery breaker.

Step 4. Waiting for the device powered off and the system shutdown is completed.

Solis S6 Series inverter does not require any regular maintenance. However, cleaning the heatsink will help the inverter dissipate heat and increase the lifetime of inverter. The dirt on the inverter can be cleaned with a soft brush.



CAUTION:

Do not touch the surface when the inverter is operating. Some parts may be hot and could cause burns. Turn OFF the inverter and let it cool down before you do any maintenance or cleaning of inverter.

The Screen and the LED status indicator lights can be cleaned with cloth if they are too dirty to be read.



Note:

Never use any solvents, abrasives, or corrosive materials to clean the inverter.

The inverter has been designed in accordance with international grid-tied standards for safety and electromagnetic compatibility requirements. Before being delivered to the customer the inverter is subjected to several tests to ensure reliability operation and reliability.

In case of a failure app will display an alarm message. In this case, the inverter may stop feeding energy into the grid. The alarm descriptions and their corresponding alarm messages are listed in Table 6.1:

Alarm Message	Failure description	Solution
ARC-FAULT	ARC detected in DC circuit	1. Check if there is an arc in the PV connection and restart inverter.
AFCI Check FAULT	AFCI module self check fault	1. Restart inverter or contact installer.
DCinj-FAULT	High DC injection current	1. Restart inverter or contact installer.
DSP-B-FAULT	Comm. failure between main and slave DSP	1. Restart inverter or contact installer.
DC-INTF	DC input overcurrent	1. Restart inverter. 2. Identify and remove the string related to the faulty MPPT. 3. Change power board.
G-IMP	High grid impedance	1. User design function allows the protection limit to be adjusted if it is allowed by electrical company.
GRID-INTF01/02	Grid interference	1. Restart inverter. 2. Change power board.
IGBT-OV-I	Over IGBT current	
IGFOL-F	Grid current tracking fail	1. Restart inverter or contact installer.
IG-AD	Grid current sampling fail	
ILeak-PRO 01/02/03/04	leakage current protection	1. Check AC and DC connection. 2. Check inverter inside cable connection.
INI-FAULT	Initialization system fault	1. Restart inverter or contact installer.
NO-Battery	Unconnected battery	1. Ensure the battery is connected properly. 2. Verify the output battery voltage is correct.
NO-GRID	No grid voltage	1. Check connections and grid switch. 2. Verify the grid voltage is correct on the AC Terminals inside the inverter wiring box.
OV-BUS	Over DC bus voltage	1. Check inverter inductor connection. 2. Check driver connection.

Alarm Message	Failure description	Solution
OV-DC01/02/03/04	Over DC voltage	1. Reduce the module number in series.
OV-DCA-I	DC input overcurrent	1. Restart inverter. 2. Identify and remove the string of the faulted MPPT. 3. Change power board.
OV-G-V01/02/03/04/05	Over grid voltage	1. Resistance of AC Cable is too high. Increase the gauge of grid cables. 2. Adjust the protection limit if it is permitted by electrical company.
OV-G-I	Over grid current	1. Restart inverter. 2. Change power board.
OV-G-F01/02	Over grid frequency	1. User design function allows the protection limit to be adjusted if it is permitted by electrical company.
OV-IgTr	AC side transient overcurrent	1. Restart inverter. 2. Return-factory repair.
OV-ILLC	LLC hardware overcurrent	
OV-VBackup	Backup overvoltage fault	
OV-TEM	Over Temperature	1. Check inverter surrounding ventilation. 2. Determine if there is direct sunlight on the inverter during hot weather.
OV-Vbatt1	The detection of battery overvoltage	1. Verify the protection point for over voltage is set correctly. 2. Restart inverter.
OV-Vbatt-H	Battery overvoltage hardware fault	1. Check if any part of the battery input circuit is tripped, ie. battery fuses, battery circuit breaker. 2. Restart inverter.
Over-Load	Backup overload fault	1. Check the load of Backup port is over rating output power or not. 2. Reduce the load of Backup port, then restart inverter.
PV ISO-PRO01/02	PV isolation protection	1. Remove all DC input, reconnect and restart inverter one by one. 2. Identify which string cause the fault and check the isolation of the string.
RelayChk-FAIL	Relay check fail	1. Restart inverter or contact installer.

Alarm Message	Failure description	Solution
UN-BUS01/02	Under DC bus voltage	1. Check inverter inductor connection. 2. Check driver connection.
UN-G-F01/02	Under grid frequency	1. Use user define function to adjust the protection limit if it's allowed by electrical company.
UN-G-V01/02	Under grid voltage	
12Power-FAULT	12V power supply fault	1. Restart inverter or contact installer.

Table 6.1 Fault message and description



NOTE:

If the inverter displays any alarm message listed in Table 6.1; please turn off the inverter and wait for 5 minutes before restarting it . If the failure persists, please contact your local distributor or the service center.

If you have any technical problems with the hybrid system, please contact the Solis after-sale service. We recommend gathering the following information before making contact in order to get timely support.

Item	Details	Supplemental Info
Inverter SN		SN from nameplate
Inverter Firmware Version		6 digits of number or letter (Check the inverter user manual for the path)
DC connections		Solar modules, numbers, configuration
Detailed description of the problem		
Battery SN, Firmware version		Check battery user manual for the path
Is it connected to Solis Monitoring Portal?		Yes/No
Take pictures showing all the cable connections in the system (Videos preferred)		If available

7. Specifications

Technical Data	S6-EH1P3.8K-H-US	S6-EH1P5K-H-US
Input DC (PV side)		
Recommended max. PV power	6080W	8000W
Max. input voltage	600V	
Rated voltage	380V	
Start-up voltage	80V	
MPPT voltage range	80-520V	
Full load MPPT voltage range	140-450V	
Max. input current per string	16A	
Max. short circuit current per string	25.6A	
Number of MPPTs/Number of strings per MPPT	2/1	3/1
Energy Storage		
Battery type	Lithium-ion	
Battery voltage range	120 - 500V	
Maximum charge/discharge current	25A	
Battery Communication	CAN/RS485	
Number of batteries per inverter	See Battery Compatibility Sheet	
AC Output (Grid)		
Rated output power	3.8kW	5kW
Max. apparent output power	3.8kW	5kW
Rated output voltage	220 V/110 V	
Rated frequency	60 Hz	
Rated output current	17.3A	22.7A
Max. output current	17.3A	22.7A
THDi	<3%	
AC Input (Grid)		
Input voltage range	193.6-242V	
Max. input current	25.9A	34.1A
Frequency range	59.5-60.5 Hz	

7. Specifications

Technical Data	S6-EH1P3.8K-H-US	S6-EH1P5K-H-US
AC Output (Backup and Off-grid)		
Rated output power	3.8kW	5kW
Max. apparent output power	6.1 kVA, 10 sec	8 kVA, 10 sec
Back-up switch time	< 10 ms	
Phase Power	220V Split-Phase	
Rated output voltage(L1-L2)/(L1/L2-N)	220 V/110 V	
AC output voltage range	193.6-242 V/97-121 V	
Rated grid frequency	60 Hz	
Frequency range	55-65Hz	
Rated AC output current	17.3A	22.7A
Max. output overcurrent protection, 10sec	27.7A	36.4A
Max. allowable phase imbalance	100%	
Backup support configurations	Dedicated loads and whole-home (with a Solis Power Hub)	
Power Factor	>0.99 (0.8 leading - 0.8 lagging)	
THDv(@linear load)	<3%	
Efficiency		
PV Max. efficiency	97.6%	
PV CEC efficiency	97.2%	
BAT charged by PV Max. efficiency	98.5%	
BAT charged/discharged to AC Max. efficiency	97.0%	
Protection		
Ground fault detection	Yes	
Residual (leakage) current detection	Yes	
Integrated AFCI (DC arc-fault circuit protection)	Yes	
DC reverse-polarity protection	Yes (PV only)	
Rapid Shutdown NEC 2017	Integrated SunSpec-certified Transmitter	
Compatible RSD Receivers	See MLRSD compatibility sheet	
Protection class/Over voltage category	I/II	

7. Specifications

Technical Data	S6-EH1P3.8K-H-US	S6-EH1P5K-H-US
General data		
Dimensions(H/W/D)	25.47*19.21*9.00 in (647*488*228.5 mm)	
Weight	44.1 lbs (20 kg)	
Topology	Transformerless	
Operation temperature range	-25 ~ +60 °C / -31 ~ +140 °F	
Ingress protection	NEMA 4X(IP66)	
Noise emission (Typical)	<30 dB (A)	
Cooling method	Natural convection	
Max.operation altitude	13120 ft (4000 m)	
Complicance	UL1699B, UL1998, FCCPart15ClassB, CAN/CSA C22.2107.1-16	
Generator support	Yes; up to 25 kW (with a Solis Power Hub)	
Features		
DC connection	1 in. knockouts for conduit (x2) on the side and bottom; Spring clamp terminals	
AC connection	2 in. knockouts for conduit (x3) on the side and bottom; Spring clamp terminals	
Interface	LED indicator lights, Bluetooth/Phone app	
Monitoring Platform	SolisCloud (modbus map and API sharing available upon request)	
Communication	RS485, Optional: Cellular, Wi-Fi, LAN	
Warranty	10 years standard (Extend to 20 years)	

7. Specifications

Technical Data	S6-EH1P6K-H-US	S6-EH1P7.6K-H-S-US
Input DC (PV side)		
Recommended max. PV power	9600W	12160W
Max. input voltage	600V	
Rated voltage	380V	
Start-up voltage	80V	
MPPT voltage range	80-520V	
Full load MPPT voltage range	155-450V	175-450V
Max. input current per string	16A	
Max. short circuit current per string	25.6A	
Number of MPPTs/Number of strings per MPPT	3/1	
Energy Storage		
Battery type	Lithium-ion	
Battery voltage range	120 - 500V	
Maximum charge/discharge current	25A	
Battery Communication	CAN/RS485	
Number of batteries per inverter	See Battery Compatibility Sheet	
AC Output (Grid)		
Rated output power	6kW	7.6kW
Max. apparent output power	6kW	7.6kW
Rated output voltage	220 V/110 V	
Rated frequency	60 Hz	
Rated output current	27.3A	34.5A
Max. output current	27.3A	34.5A
THDi	<3%	
AC Input (Grid)		
Input voltage range	193.6-242V	
Max. input current	40.9A	51.8A
Frequency range	59.5-60.5 Hz	

7. Specifications

Technical Data	S6-EH1P6K-H-US	S6-EH1P7.6K-H-S-US
AC Output (Backup and Off-grid)		
Rated output power	6kW	7.6kW
Max. apparent output power	9.6 kVA, 10 sec	12.2 kVA, 10 sec
Back-up switch time	< 10 ms	
Phase Power	220V Split-Phase	
Rated output voltage(L1-L2)/(L1/L2-N)	220 V/110 V	
AC output voltage range	193.6-242 V/97-121 V	
Rated grid frequency	60 Hz	
Frequency range	55-65Hz	
Rated AC output current	27.3A	34.5A
Max. output overcurrent protection, 10sec	43.6A	55.5A
Max. allowable phase imbalance	100%	
Backup support configurations	Dedicated loads and whole-home (with a Solis Power Hub)	
Power Factor	>0.99 (0.8 leading - 0.8 lagging)	
THDv(@linear load)	<3%	
Efficiency		
PV Max. efficiency	97.6%	
PV CEC efficiency	97.2%	
BAT charged by PV Max. efficiency	98.5%	
BAT charged/discharged to AC Max. efficiency	97.0%	
Protection		
Ground fault detection	Yes	
Residual (leakage) current detection	Yes	
Integrated AFCI (DC arc-fault circuit protection)	Yes	
DC reverse-polarity protection	Yes (PV only)	
Rapid Shutdown NEC 2017	Integrated SunSpec-certified Transmitter	
Compatible RSD Receivers	See MLRSD compatibility sheet	
Protection class/Over voltage category	I/II	

7. Specifications

Technical Data	S6-EH1P6K-H-US	S6-EH1P7.6K-H-S-US
General data		
Dimensions(H/W/D)	25.47*19.21*9.00 in (647*488*228.5 mm)	
Weight	44.1 lbs (20 kg)	
Topology	Transformerless	
Operation temperature range	-25 ~ +60 °C / -31 ~ +140 °F	
Ingress protection	NEMA 4X(IP66)	
Noise emission (Typical)	<30 dB (A)	
Cooling method	Natural convection	
Max.operation altitude	13120 ft (4000 m)	
Complicance	UL1699B, UL1998, FCCPart15ClassB, CAN/CSA C22.2107.1-16	
Generator support	Yes; up to 25 kW (with a Solis Power Hub)	
Features		
DC connection	1 in. knockouts for conduit (x2) on the side and bottom; Spring clamp terminals	
AC connection	2 in. knockouts for conduit (x3) on the side and bottom; Spring clamp terminals	
Interface	LED indicator lights, Bluetooth/Phone app	
Monitoring Platform	SolisCloud (modbus map and API sharing available upon request)	
Communication	RS485, Optional: Cellular, Wi-Fi, LAN	
Warranty	10 years standard (Extend to 20 years)	

7. Specifications

Technical Data	S6-EH1P7.6K-H-L-US	S6-EH1P8K-H-US
Input DC (PV side)		
Recommended max. PV power	12160W	12800W
Max. input voltage	600V	
Rated voltage	380V	
Start-up voltage	80V	
MPPT voltage range	80-520V	
Full load MPPT voltage range	175-450V	185-450V
Max. input current per string	16A	
Max. short circuit current per string	25.6A	
Number of MPPTs/Number of strings per MPPT	4/1	
Energy Storage		
Battery type	Lithium-ion	
Battery voltage range	120 - 500V	
Maximum charge/discharge current	50A	
Battery Communication	CAN/RS485	
Number of batteries per inverter	See Battery Compatibility Sheet	
AC Output (Grid)		
Rated output power	7.6kW	8kW
Max. apparent output power	7.6kW	8kW
Rated output voltage	220 V/110 V	
Rated frequency	60 Hz	
Rated output current	34.5A	36.4A
Max. output current	34.5A	36.4A
THDi	<3%	
AC Input (Grid)		
Input voltage range	193.6-242V	
Max. input current	51.8A	54.5A
Frequency range	59.5-60.5 Hz	

7. Specifications

Technical Data	S6-EH1P7.6K-H-L-US	S6-EH1P8K-H-US
AC Output (Backup and Off-grid)		
Rated output power	7.6kW	8kW
Max. apparent output power	12.2 kVA, 10 sec	12.8 kVA, 10 sec
Back-up switch time	< 10 ms	
Phase Power	220V Split-Phase	
Rated output voltage(L1-L2)/(L1/L2-N)	220 V/110 V	
AC output voltage range	193.6-242 V/97-121 V	
Rated grid frequency	60 Hz	
Frequency range	55-65Hz	
Rated AC output current	34.5A	36.4A
Max. output overcurrent protection, 10sec	55.5A	58.2A
Max. allowable phase imbalance	100%	
Backup support configurations	Dedicated loads and whole-home (with a Solis Power Hub)	
Power Factor	> 0.99 (0.8 leading - 0.8 lagging)	
THDv(@linear load)	<3%	
Efficiency		
PV Max. efficiency	97.6%	
PV CEC efficiency	97.2%	
BAT charged by PV Max. efficiency	98.5%	
BAT charged/discharged to AC Max. efficiency	97.0%	
Protection		
Ground fault detection	Yes	
Residual (leakage) current detection	Yes	
Integrated AFCI (DC arc-fault circuit protection)	Yes	
DC reverse-polarity protection	Yes (PV only)	
Rapid Shutdown NEC 2017	Integrated SunSpec-certified Transmitter	
Compatible RSD Receivers	See MLRSD compatibility sheet	
Protection class/Over voltage category	I/II	

7. Specifications

Technical Data	S6-EH1P7.6K-H-L-US	S6-EH1P8K-H-US
General data		
Dimensions(H/W/D)	26.61*21.85*9.39 in (676*555*238.5 mm)	
Weight	81.04 lbs (36.76 kg)	
Topology	Transformerless	
Operation temperature range	-25 ~ +60 °C / -31 ~ +140 °F	
Ingress protection	NEMA 4X(IP66)	
Noise emission (Typical)	<30 dB (A)	
Cooling method	Natural convection	
Max.operation altitude	13120 ft (4000 m)	
Complicance	UL1699B, UL1998, FCCPart15ClassB, CAN/CSA C22.2107.1-16	
Generator support	Yes; up to 25 kW (with a Solis Power Hub)	
Features		
DC connection	1 in. knockouts for conduit (x2) on the side and bottom; Spring clamp terminals	
AC connection	2 in. knockouts for conduit (x3) on the side and bottom; Spring clamp terminals	
Interface	LED indicator lights, Bluetooth/Phone app	
Monitoring Platform	SolisCloud (modbus map and API sharing available upon request)	
Communication	RS485, Optional: Cellular, Wi-Fi, LAN	
Warranty	10 years standard (Extend to 20 years)	

7. Specifications

Technical Data	S6-EH1P10K-H-US	S6-EH1P11.4K-H-US
Input DC (PV side)		
Recommended max. PV power	16000W	18240W
Max. input voltage	600V	
Rated voltage	380V	
Start-up voltage	80V	
MPPT voltage range	80-520V	
Full load MPPT voltage range	230-450V	245-450V
Max. input current per string	16A	
Max. short circuit current per string	25.6A	
Number of MPPTs/Number of strings per MPPT	4/1	
Energy Storage		
Battery type	Lithium-ion	
Battery voltage range	120 - 500V	
Maximum charge/discharge current	50A	
Battery Communication	CAN/RS485	
Number of batteries per inverter	See Battery Compatibility Sheet	
AC Output (Grid)		
Rated output power	10kW	11.4kW
Max. apparent output power	10kW	11.4kW
Rated output voltage	220 V/110 V	
Rated frequency	60 Hz	
Rated output current	45.5A	51.8A
Max. output current	45.5A	51.8A
THDi	<3%	
AC Input (Grid)		
Input voltage range	193.6-242V	
Max. input current	68.2A	77.7A
Frequency range	59.5-60.5 Hz	

7. Specifications

Technical Data	S6-EH1P10K-H-US	S6-EH1P11.4K-H-US
AC Output (Backup and Off-grid)		
Rated output power	10kW	11.4kW
Max. apparent output power	16 kVA, 10 sec	18.2 kVA, 10 sec
Back-up switch time	< 10 ms	
Phase Power	220V Split-Phase	
Rated output voltage(L1-L2)/(L1/L2-N)	220 V/110 V	
AC output voltage range	193.6-242 V/97-121 V	
Rated grid frequency	60 Hz	
Frequency range	55-65Hz	
Rated AC output current	45.5A	51.8A
Max. output overcurrent protection, 10sec	72.7A	82.7A
Max. allowable phase imbalance	100%	
Backup support configurations	Dedicated loads and whole-home (with a Solis Power Hub)	
Power Factor	>0.99 (0.8 leading - 0.8 lagging)	
THDv(@linear load)	<3%	
Efficiency		
PV Max. efficiency	97.6%	
PV CEC efficiency	97.2%	
BAT charged by PV Max. efficiency	98.5%	
BAT charged/discharged to AC Max. efficiency	97.0%	
Protection		
Ground fault detection	Yes	
Residual (leakage) current detection	Yes	
Integrated AFCI (DC arc-fault circuit protection)	Yes	
DC reverse-polarity protection	Yes (PV only)	
Rapid Shutdown NEC 2017	Integrated SunSpec-certified Transmitter	
Compatible RSD Receivers	See MLRSD compatibility sheet	
Protection class/Over voltage category	I/II	

7. Specifications

Technical Data	S6-EH1P10K-H-US	S6-EH1P11.4K-H-US
General data		
Dimensions(H/W/D)	26.61*21.85*9.39 in (676*555*238.5 mm)	
Weight	81.04 lbs (36.76 kg)	
Topology	Transformerless	
Operation temperature range	-25 ~ +60 °C / -31 ~ +140 °F	
Ingress protection	NEMA 4X(IP66)	
Noise emission (Typical)	<30 dB (A)	
Cooling method	Natural convection	
Max.operation altitude	13120 ft (4000 m)	
Complicance	UL1699B, UL1998, FCCPart15ClassB, CAN/CSA C22.2107.1-16	
Generator support	Yes; up to 25 kW (with a Solis Power Hub)	
Features		
DC connection	1 in. knockouts for conduit (x2) on the side and bottom; Spring clamp terminals	
AC connection	2 in. knockouts for conduit (x3) on the side and bottom; Spring clamp terminals	
Interface	LED indicator lights, Bluetooth/Phone app	
Monitoring Platform	SolisCloud (modbus map and API sharing available upon request)	
Communication	RS485, Optional: Cellular, Wi-Fi, LAN	
Warranty	10 years standard (Extend to 20 years)	

8.1 FCC Certification

This device complies with part 15 of the FCC Rules. Operation is subject to the following two conditions: (1) This device may not cause harmful interference, and (2) this device must accept any interference received, including interference that may cause undesired operation.



FCC WARNING:

Any Changes or modifications not expressly approved by the party responsible for compliance could void the user's authority to operate the equipment.



NOTE:

This equipment has been tested and found to comply with the limits for a Class B digital device, pursuant to part 15 of the FCC Rules. These limits are designed to provide reasonable protection against harmful interference in a residential installation. This equipment generates uses and can radiate radio frequency energy and, if not installed and used in accordance with the instructions, may cause harmful interference to radio communications. However, there is no guarantee that interference will not occur in a particular installation. If this equipment does cause harmful interference to radio or television reception, which can be determined by turning the equipment off and on, the user is encouraged to try to correct the interference by one or more of the following measures:

- Reorient or relocate the receiving antenna.
- Increase the separation between the equipment and receiver.
- Connect the equipment into an outlet on a circuit different from that to which the receiver is connected.
- Consult the dealer or an experienced radio/TV technician for help.

This equipment complies with FCC radiation exposure limits set forth for an uncontrolled environment. This equipment should be installed and operated with minimum distance 20cm between the radiator & your body.

Ginlong Technologies Co., Ltd.

No. 57 Jintong Road, Binhai Industrial Park, Xiangshan, Ningbo,
Zhejiang, 315712, P.R.China.

Tel: +86 (0)574 6578 1806

Fax: +86 (0)574 6578 1606

Email:info@ginlong.com

Web:www.ginlong.com

Please adhere to the actual products in case of any discrepancies in this user manual.

If you encounter any problem on the inverter, please find out the inverter S/N
and contact us, we will try to respond to your question ASAP.



**SunSpec
Certified**



**Comply with CA Rule 21/
Certified to UL 1741 SA
Certified to UL Std. No. 1741-Second Edition
& CSA-C22.2 No.107.1-16**